

# DURALLOY®

## 171 & 191 MULTIMIG OWNER'S MANUAL



## SAFETY

Welding and cutting is dangerous to the operator, people in or near the working area, and the surrounding, if the machine is not correctly operated. Therefore, the performance of welding/cutting must only be under the strict and comprehensive observance of all relevant safety regulations. Please read and understand this instruction manual carefully before the installation and operation.

- The switching of function modes is possibly damaging to the machine, while the welding operation is performed.
- Do not disconnect the electrode-holder cable with the machine, before the performance of welding.
- A safety switch is necessary to prevent the machine from electric-leakage.
- Welding tools should be of high quality.
- Operators should be qualified.

### **Electric shock: It could be fatal!**

- Connect the earth cable according to standard regulation.
- Avoid all contact with live electrical parts of the welding circuit, electrodes and wires with bare hands. It is necessary for the operator to wear dry welding gloves while he performs the welding task.
- The operator should keep the working piece insulating from himself/herself.

### **Smoke and gas generated while welding or cutting: harmful to people's health.**

- Avoid breathing the smoke and gas generated while welding or cutting.
- Keep the working area well ventilated.

### **Arc rays: harmful to people's eyes and skin.**

- Wear welding helmet, anti-radiation glass and work clothes while the welding operation is performed.
- Measures also should be taken to protect people in or near the working area.

### **Fire hazard**

- The welding splash may cause fire, thus remove flammable material away from the working place.
- Have a fire extinguisher nearby, and have a trained person ready to use it.

### **Noise: possibly harmful to people's hearing.**

- Noise is generated while welding/cutting, wear approved ear protection if noise level is high

### **Machine fault:**

- Consult this instruction manual.
- Contact your local dealer or supplier for further advice.

## GENERAL DESCRIPTION

This welding machine is composed of the inverter MIG welder power supply with variable voltage output external characteristics manufactured with advanced IGBT inverter technology designed by our company.

With high-power component IGBT, the inverter converts the DC voltage, which is rectified from input 50Hz/60Hz AC voltage, to high-frequency 20 KHz AC voltage; as a consequence, the voltage is transformed and rectified. The features of this machine are as follows:

- IGBT inverter technology, current control, high quality with stable performance
- Closed feedback circuit, variable voltage output, great ability of balance voltage up to  $\pm 15\%$ ;
- Electron reactor control, stable welding, low spatter, deep penetration, excellent weld bead shape.
- Welding voltage can be preset, and the voltmeter displays the preset voltage value when not welding.
- Both welding current and welding voltage can be observed at the same time.
- Burn back time is adjustable.
- Slow wire feeding during arc starting, removes the melted ball after welding offering reliable arc starting;
- Wire feeding part is separated from the welding machine with wide welding operation range.
- Small-sized, light-weight, easy to operate, economical, practical.

### Unpacking your machine:

When unpacking, inspect carefully for any damage that may have occurred during transit. Check carefully to ensure all the contents on the list below have been received in good condition

Included items:



- 171 & 191 MULTIMIG welder
- Owner's Manual



MMA lead and holder



Earth lead and clamp



3m MIG torch



Gas Hose



FC roller



V roller



Regulator

### Operating environment:

Adequate ventilation is required to provide proper cooling for the machine. Ensure that the machine is placed on a stable level surface where clean cool air can easily flow through the unit. The machine has electrical components and control circuit boards which will be damaged by excessive dust and dirt, so a clean operating environment is essential.

### LIFT TIG

Needed items: inverter welder with LIFT TIG function 2 Piece TIG Torch with one output power cable and one Gas Hose.

The operation of LIFT TIG is shown as below:

The output power cable connects with the negative output terminal, and the Gas hose connects with the gas regulator on the gas bottle. There is a nut on the gas hose, which can connect with the gas regulator. Then open the valve of the gas bottle and open the valve of the gas regulator, you can control the gas flow by adjusting the gas regulating valve on the TIG Torch. Make the tungsten electrode touch the workpiece, lift the TIG Torch up, this will produce the arc.

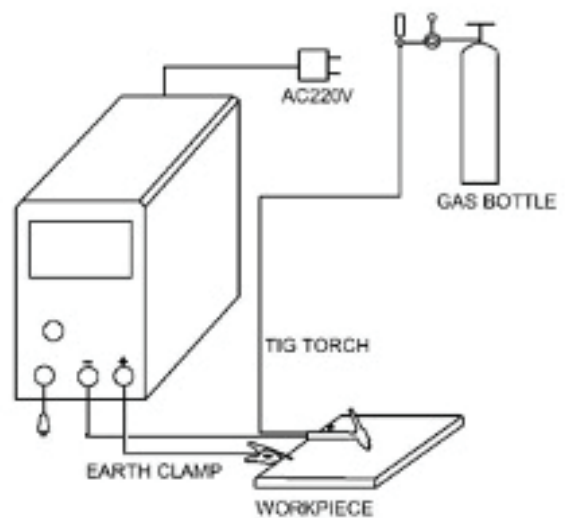

## MAIN PARAMETER

MODEL	171MMIG			191MMIG		
Power supply voltage	240±10%			240±10%		
Rated input capacity	5.7	4.3	7.3	7.8	6	7.5
Frequency(inverter)	45			45		
Rated input current	24\10	29\10	32\10	32\15	26\13	32\15
Output current range	50-175	10-160	10-140	50-200	10-200	10-150
Function	MIG	TIG	MMA	MIG	TIG	MMA
Duty cycle (40°C 10min)	15% 160A	15% 160A	158% 140A	20% 200A	20% 200A	20% 150A
	60% 80A	60% 100A	60% 130A	60% 115A	60% 115A	60% 115A
	100% 62A	100% 80A	100% 90A	100% 105A	100% 105A	100% 95A
No load voltage	54			51		
Efficiency	85			85		
Power factor	0.76			0.76		
IP	21S			21S		
Insulation class	H			H		
Cooling way	FAN & AIR			FAN & AIR		
Dimension	460x170x310			460x170x310		
Wire diameter	0.6-0.8-1.0		Ø2.5,Ø3.2	0.6-0.8-1.0		Ø2.5,Ø3.2
Electrode type			6013,7018,etc.			6013,7018,etc.
Net weight	10			10		

Note: The welding duty cycle is the percentage of actual continuous welding time that can occur in a ten minute cycle. For example: 15% at 200amps- this means the welder can weld continuously at 200 amps for 1.5 minutes and then the unit will need to be rested for 8.5 minutes.

The duty cycle can be affected by the environment in which the welder is used. In areas with temperatures exceeding 40°C, the duty cycle will be less than stated. In areas less than 40°C, higher duty cycles have been obtained

All tests on duty cycles have been carried out at 40°C with a 50%. So in practical working conditions the duty cycles will be much greater than those stated above.

## STRUCTURE OF WELDER



1. Gas selection
2. VRD/2T/4T Selection function
3. welding mode selection button: MMA/LIFT TIG/MIG
4. Voltage/voltage refine/error digital display
5. Current/inductance/wire feed speed digital display
6. Wire diameter (Synergy)selection/manual mode
7. Gas check
8. Wire check
9. welding parameter adjustment knob
10. Function button: adjust the inductance in MIG mode; adjust the hot start and arc force in MMA mode.
11. MIG Torch 'Euro Style' Connection Socket
12. Positive (+) Welding Output Terminal
13. Negative (-) Welding Output Terminal
14. Polarity conversion line

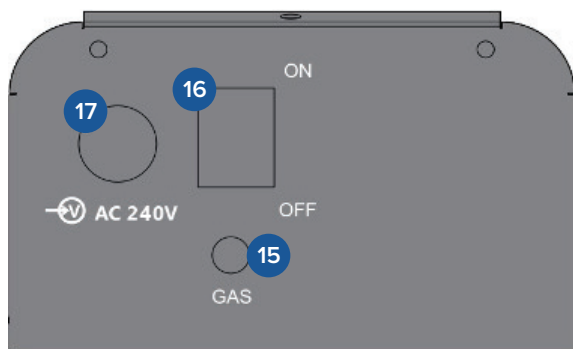

15. welding gas inlet
16. power switch
17. power cable

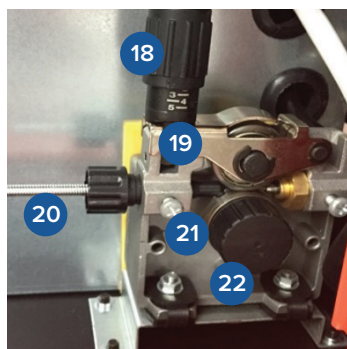

18. Wire tension adjustment
19. Wire tension arm & support roller
20. Wire input guide
21. Wire drive roller
22. Drive roller retainer

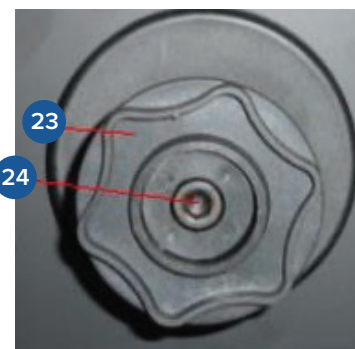

23. Wire spool retainer
24. Spool brake adjustment



25. Torch trigger switch
26. Torch "Euro" connector



27. Workpiece earth clamp
28. Earth lead quick connector



29. Conical gas nozzle/shroud
30. Welding MIG
31. Shroud spring
32. MIG adapter

## INSTALLATION

### 5.1. MIG WELDING SET UP & OPERATION

#### 5.1.1 Fitting the spool

5.1.1.1 Open the cover door for the wire feed compartment. Remove the wire spool retainer (23) by threading off anti clockwise.

5.1.1.2 Fit the 200mm diameter wire spool to the spool holder, ensuring the end of the wires exits towards the wire feeder from the bottom of the spool. Refit the wire spool retainer (23) and tighten finger tight.

5.1.1.3 Set the spool brake tension by rotating the adjustment screw (24) using an Allen wrench. Clockwise to increase brake tension, anti-clockwise to decrease brake tension. The spool brake tension should be set so that the spool can rotate freely, but does not continue to rotate once the wire feed stops. This may need to be adjusted as the wire is used up and the spool weight decreases.

#### 5.1.2 Loading wire feeder

5.1.2.1 Release the wire feeder tension arm (19) by pivoting the wire feed tension adjuster (18) as pictured below

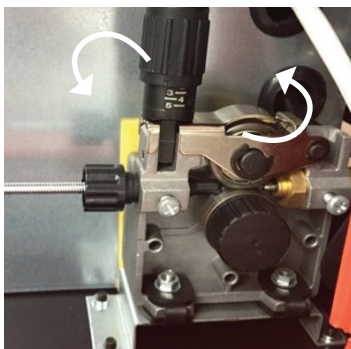

5.1.2.2 Check the wire drive roller (21) groove matches the selected MIG wire type and size. The drive roller will have two different sized grooves, the size of the groove in use is stamped on the side of the drive roller. For flux cored 'soft' wire, such as that used in gasless MIG welding, the drive roller groove has a serrated profit. For solid 'hard' MIG wire, the roller groove has a 'v' shaped profile

5.1.2.3 The drive roller (21) is removed by threading the drive roller retainer (22) off in the anti-clockwise direction. Once the correct drive roller profile is selected, re-fit the drive roller.

5.1.2.4 Thread the MIG wire from the spool through the input guide tube (20), through the roller groove and into the outlet guide tube

5.1.2.5 Replace the tension arm (19) and the tension adjustment (18). Double check the wire has located correctly in the drive roller groove.

5.1.2.6 Adjusting wire feed tension: this is accomplished by winding the knob on the wire tension adjustment arm (18). Clockwise will increase tension, anti-clockwise will decrease tension. There is a numbered scale on the tensioner to

indicate the position. Ideal tension should be as little as possible, while maintaining a consistent wire feed with no drive roller slippage. Check all other possible causes of slippage, such as; incorrect/ worn drive roller, worn/ damaged torch consumables, blocked/ damaged torch feed liner, before increasing feed tension.



**Warning! - Before changing the feed roller or wire spool, ensure that the mains power is switched off**



**Warning! - The use of excessive feed tension will cause rapid and premature wear of the drive roller, the support bearing and the drive motor.**

#### 5.1.3 Setup for gasless MIG welding operation

5.1.3.1 Connect the MIG Torch Euro Connector (26) to the torch socket on the front of the welder (11). Secure by firmly hand tightening the threaded collar on the MIG Torch Euro Connector clockwise.

5.1.3.2 Check that the correct flux cored, gasless wire, matching drive roller (21) and welding tip (30) are fitted

5.1.3.3 Connect Torch Connection Power Lead (14) to the negative (-) welding output terminal (13).

5.1.3.4 Connect Earth Lead Quick Connector (28) to the positive (+) output welding terminal (12). See picture below.

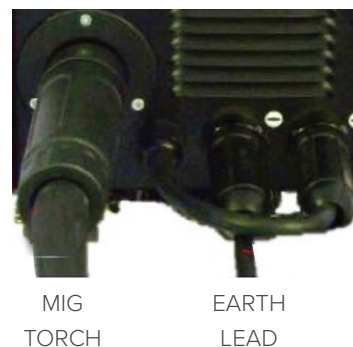

5.1.3.5 Connect Earth Clamp (27) to the work piece. Contact with workpiece must be strong contact with clean, bare metal, with no corrosion, paint or scale at the contact point.

#### 5.1.4 Setup for gas shielded MIG welding operation

Note - Gas shielded MIG welding requires a shielding gas supply, gas regulator and gas shielded MIG wire.

5.1.4.1 Connect the MIG Torch Euro Connector (26) to the torch socket on the front of the welder (11). Secure by firmly hand tightening the threaded collar on the MIG Torch Euro Connector clockwise.

5.1.4.2 Check that the correct gas shielded wire, matching drive roller (21) and welding tip (30) are fitted



## INSTALLATION *continued*

5.1.4.3 Connect Torch Connection Power Lead (14) to the positive (+) welding output terminal (12)

5.1.4.4 Connect Earth Lead Quick Connector (28) to the negative (-) output welding terminal (13). See picture below

5.1.4.5 Connect Earth Clamp (27) to the work piece. Contact with workpiece must be strong contact with clean, bare metal, with no corrosion, paint or scale at the contact point.

5.1.4.6 Connect the gas regulator and gas line to the inlet on the rear panel (15). If the regulator is equipped with a flow gauge, the flow should be set between 8 – 15 L/minute depending on application. If gas regulator is not equipped with a flow gauge, adjust pressure so gas can just be heard coming out of the torch conical nozzle (29). It is recommended that gas flow is checked again, just prior to starting weld this can be done by triggering the MIG torch with the unit powered up.

### Connection of Shield Gas

Connect the CO2 hose, which come from the wire feeder to the copper nozzle of gas bottle. The gas supply system includes the gas bottle, the air regulator and the gas hose, the heater cable should be inserted into the socket of machine's back, and use the hose clamp to tighten it to prevent leaking or air-in, so that the welding spot is protected.

Please note:

1. Leakage of shielding gas affects the performance of arc welding.
2. Avoid the sun shine on the gas cylinder to eliminate the possible explosion of gas cylinder due to the increasing pressure of gas resulted from the heat.
3. It is extremely forbidden to hit gas cylinder and lay the cylinder horizontally.
4. Ensure no person is up against the regulator, before the gas release or shut the gas output.
5. The gas output volume meter should be installed vertically to ensure the precisely measuring.
6. Before the installation of gas regulator, release and shut the gas for several time in order to remove the possible dust on the sieve to avail the gas output.

Note: Since the arc of MIG welding is much stronger than that of MMA welding, please wear welding helmet and protective clothing.

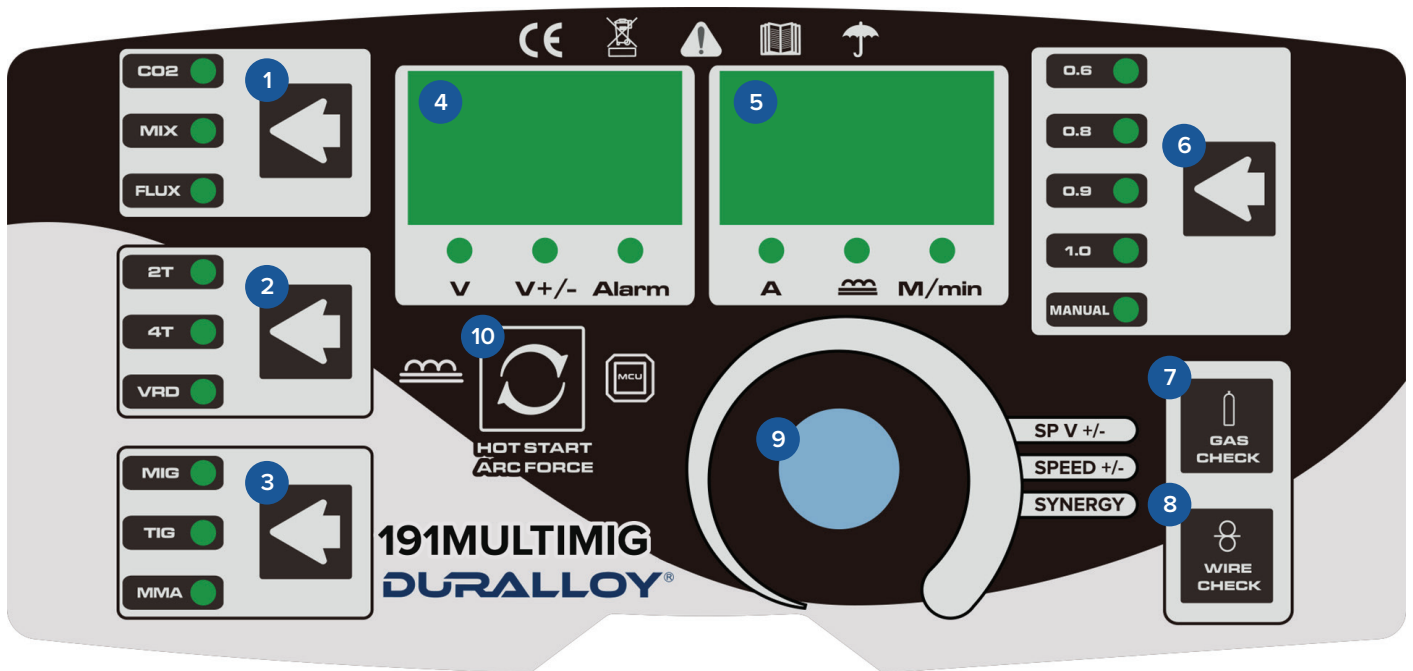

## 5.1.5 Controls for MIG welding

5.1.5.1 Gas selection: CO2--ordinary CO2 gas; MIX--20% CO2 80% argon; FLUX-- flux cored

5.1.5.2 Function selection: 2T in MIG mode/4T in MIG mode; VRD in MMA mode

5.1.5.3 Welding mode selection: MIG welding mode; TIG welding mode; MMA welding mode

5.1.5.4 Voltage meter: in MIG mode it shows setting voltage and welding voltage; in other modes no voltage will be showed.

Warning! - Disconnect the power supply when the Alarm light flash.

5.1.5.5 Current meter: in MIG mode it shows wire feed speed, welding current, inductance; in MMA mode it shows current, hot start current, arc force current.

5.1.5.6 Wire diameter selection: in Synergy mode, select the wire diameter, press the 9 adjustment knob, the voltage can be adjusted by  $\pm 1V$ ; in Separate mode, welding current and welding voltage can be adjusted separately--press the button one time to select voltage or current separate adjustment; This button cannot work in MMA or TIG mode.

5.1.5.7 Gas check: gas check function, the button cannot work in MMA or TIG mode.

5.1.5.8 Wire check: wire fast feed button--short press this button and

5.1.5.9 Adjustment knob: In MIG mode-- voltage adjustment, inductance adjustment, wire feed speed adjustment, current adjustment; In MMA mode -- inductance adjustment, hot start current adjustment; In TIG mode--current adjustment.

5.1.5.10 Mode selection: Hot start function, Arc force function, Inductance selection (Hot start function, the voltage meter shows HOL; Arc force, the voltage meter shows FOG)

**Note:** this MIG welding machine MIG welding can be both synergic and separate, select the wire feed speed the voltage parameter will be matched automatically. Please select the wire diameter according to the wire you use. Voltage refine initialization value is 0, refine the voltage by  $\pm 1V$  according to different kinds of gas. In synergy mode, the base gas is CO2, to lower the voltage by 2-3V for mix gas. Inductance initialization value is 0, adjust range  $\pm 10$ .

**Note:** for flux cored wire, connect the Polarity conversion line to Negative (-) Welding Output Terminal, connect the earth clamp to Positive (+) Welding Output Terminal; For ordinary wire, connect the Polarity conversion line to Positive (+) Welding Output Terminal, connect the earth clamp to Negative (-) Welding Output Terminal



## WELDING SETTINGS QUICK REFERENCE CHART

MULTIMIG 171 & 191 REFERENCE CHART										
Welding Parameter					Material Thickness					
Welding Material	Wire Type	Polarity	Wire Size	Shielding Gas	1.0mm	2.0mm	3.0mm	4.0mm	5.0mm	6.0mm
Settings Key: Voltage/ Wire speed										
Mild Steel	Self Shielded Flux Core	Torch Negative (-)	0.8mm	N/A	-	14.0/2.7	16.2/3.0	18.5/6.1	24.5/9.0	-
Mild Steel	Self Shielded Flux Core	Torch Negative (-)	0.9mm	N/A	-	16.3/2.0	18.8/3.6	20.2/4.1	21.0/7.5	21.6/9.0
Mild Steel	Solid Wire ER70S-6	Torch Positive (+)	0.6mm	75% Argon + 25% CO2	15.9/3.4	19.5/7.8	-	-	-	-
Mild Steel	Solid Wire ER70S-6	Torch Positive (+)	0.8mm	75% Argon + 25% CO2	12.8/2.0	14.1/3.3	17.5/6.6	20.0/8.2	21.0/9.0	21.0/9.0
Mild Steel	Solid Wire ER70S-6	Torch Positive (+)	0.6mm	100% CO2	14.2/2.1	19.8/8.1	-	-	-	-
Mild Steel	Solid Wire ER70S-6	Torch Positive (+)	0.8mm	100% CO2	13.6/2.3	14.4/3.6	18.4/4.2	21.1/8.5	22.6/9.0	-

Use this chart as a guide only, as optimal settings will vary with joint type and operator technique. Cells left blank are not a recommended configuration.

## BASIC WELDING GUIDE

### MIG (GMAW/FCAW) Basic Welding Technique

Two different welding processes are covered in this section (GMAW and FCAW), with the intention providing the very basic concepts in using the MIG mode of welding, where a welding gun is hand held, and the electrode (welding wire) is fed into a weld puddle, and the arc is shielded by an inert welding grade shielding gas or inert welding grade shielding gas mixture.

### GAS METAL ARC WELDING (GMAW)

This process, also known as MIG welding, CO2 welding, Micro Wire Welding, short arc welding, dip transfer welding, wire welding etc., is an electric arc welding process which fuses together the parts to be welded by heating them with an arc between a solid continuous, consumable electrode and the work. Shielding is obtained from an externally supplied welding grade shielding gas or welding grade shielding gas mixture. The process is normally applied semi automatically; however the and fairly thick steels, and some non-ferrous metals in all positions.

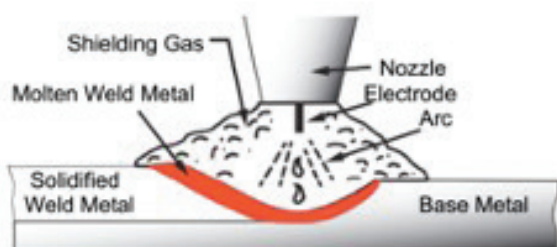

**GMAW Process**

### FLUX CORED ARC WELDING (FCAW)

This is an electric arc welding process which fuses together the parts to be welded by heating them with an arc between a continuous flux filled electrode wire and the work. Shielding is obtained through decomposition of the flux within the tubular wire. Additional shielding may or may not be obtained from an externally supplied gas or gas mixture. The process is normally applied semi automatically; however the process may be applied automatically or by machine. It is commonly used to weld large diameter electrodes in the flat and horizontal position and small electrode diameters in all positions. The process is used to a lesser degree for welding stainless steel and for overlay work.

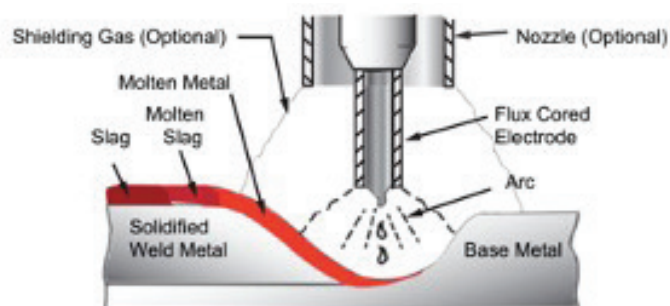

**FCAW Process**

## POSITION OF MIG TORCH

The angle of MIG torch to the weld has an effect on the width of the weld

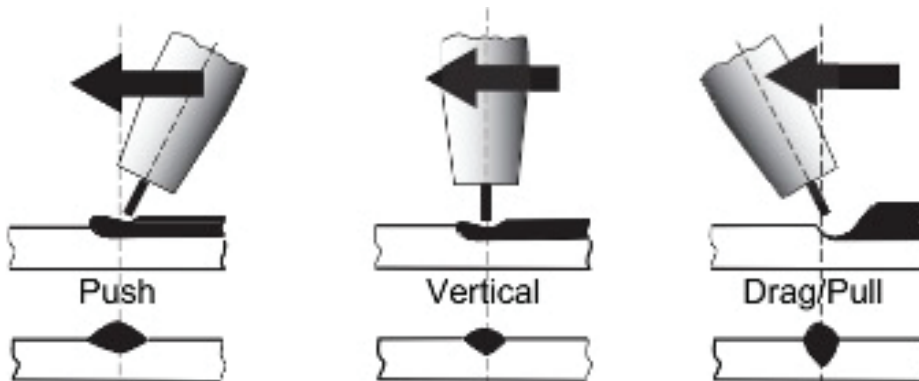

The welding gun should be held at an angle to the weld joint. (See Secondary Adjustment Variables below) Hold the gun so that the welding seam is viewed at all times. Always wear the welding helmet with proper filter lenses and use the proper safety equipment.

### CAUTION

Do not pull the welding gun back when the arc is established. This will create excessive wire extension (stick-out) and make a very poor weld.

The electrode wire is not energized until the gun trigger switch is depressed. The wire may therefore be placed on the seam or joint prior to lowering the helmet.

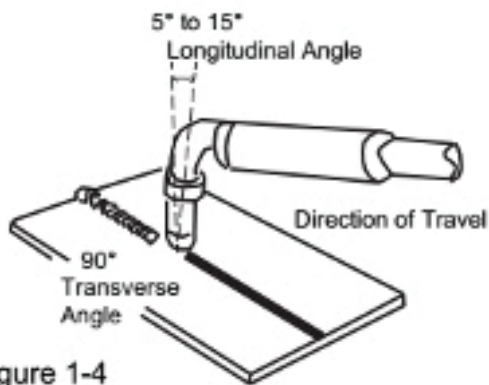

Figure 1-4

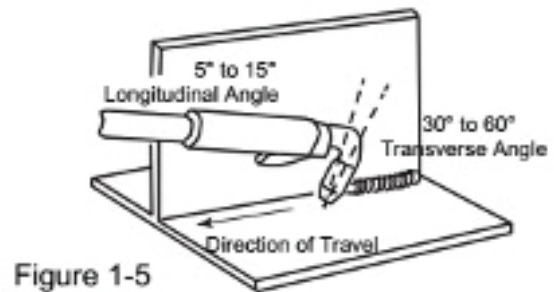
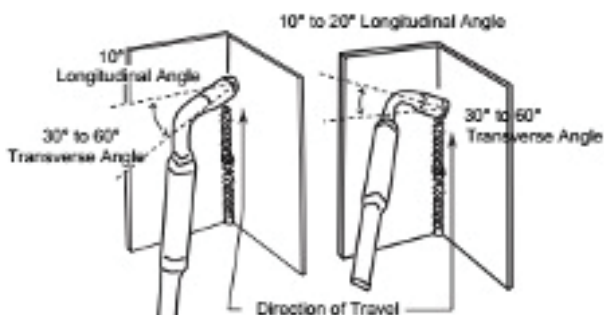

Figure 1-5



Vertical Fillet Welds  
Figure 1-6

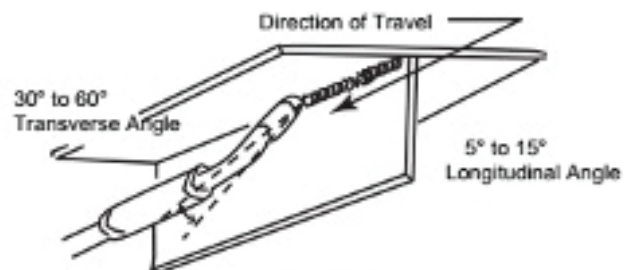

Figure 1-7

## DISTANCE FROM THE MIG TORCH NOZZLE TO THE WORK PIECE

The electrode wire stick out from the MIG Torch nozzle should be between 10mm to 20.0mm. This distance may vary depending on the type of joint that is being welded

### Travel Speed

- The speed at which the molten pool travels influences the width of the weld and penetration of the welding run

### MIG Welding (GMAW) Variables

- Most of the welding done by all processes is on carbon steel. The items below describe the welding.
- Variables in short-arc welding of 24gauge (0.024", 0.6mm) to ¼" (6.4mm) mild sheet or plate. The applied techniques and end results in the GMAW process are controlled by these variables.

### Preselected Variables

- Preselected variables depend upon the type of material being welded, the thickness of the material, the welding position, the deposition rate and the mechanical properties. These variables are:
- Type of electrode wire
- Size of electrode wire
- Type of gas (not applicable to self-shielding wires FCAW)
- Gas flow rate (not applicable to self-shielding wires FCAW)

### Primary Adjustable Variables

- These control the process after preselected variables have been found. They control the penetration, bead width, bead height, arc stability, deposition rate and weld soundness. They are:
- Arc Voltage
- Welding current (wire feed speed)
- Travel speed

### Secondary Adjustable Variables

These variables cause changes in primary adjustable variables which in turn cause the desired change in the bead formation. They are:

- Stick-out** (distance between the end of the contact tube (tip) and the end of the electrode wire). Maintain at about 10mm stick-out

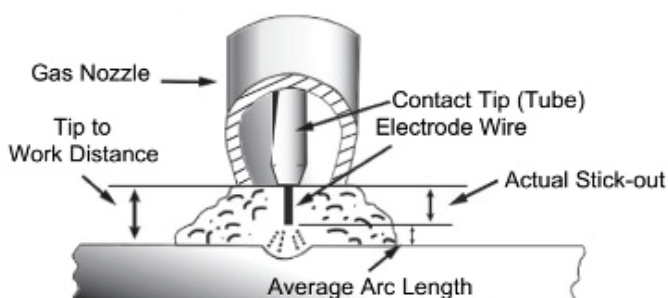

- Wire Feed Speed.** Increase in wire feed speed increases weld current, Decrease in wire feed speed decreases weld current
- Nozzle Angle.** This refers to the position of the welding gun in relation to the joint. The transverse angle is usually one half the included angle between plates forming the joint. The longitudinal angle is the angle between the Centre line of the welding gun and a line perpendicular to the axis of the weld. The longitudinal angle is generally called the Nozzle Angle and can be either trailing (pulling) or leading (Pushing). Whether the operator is left handed or right handed has to be considered to realize the effects of each angle in relation to the direction of travel.

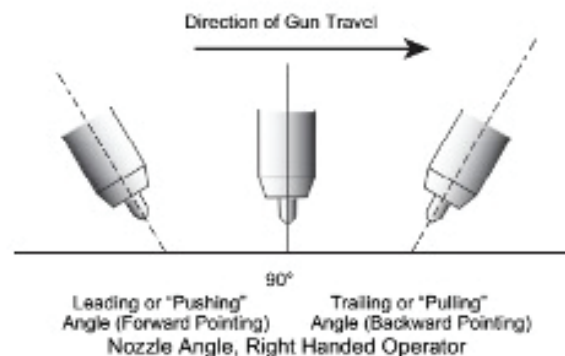
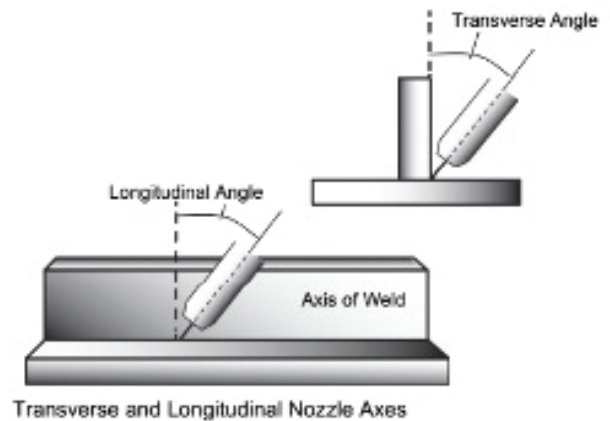

## ESTABLISHING THE ARC AND MAKING WELD BEADS

Before attempting to weld on a finished piece of work, it is recommended that practice welds be made on a sample metal of the same material as that of the finished piece

The easiest welding procedure for the beginner to experiment with MIG welding is the flat position. The equipment is capable of flat, vertical and overhead positions.

For practicing MIG welding, secure some pieces of 16 or 18 gauge (0.06" 1.5mm or 0.08" 2.0mm) mild steel plate 6" x 6" (150 x 150mm). Use 0.030" (0.8mm) flux cored gasless wire or a solid wire with shielding gas

## SETTING OF THE POWER SOURCE

Power source and Wire feeder setting requires some practice by the operator, as the welding plant has two control settings that have to balance. These are the Wire speed control and the welding Voltage Control. The welding current is determined by the Wire speed control, the current will increase with increase Wire speed, resulting in a shorter arc. Less wire speed will reduce the current and lengthen the arc. Increasing the welding voltage hardly alters the current level, but lengthens the arc. By decreasing voltage, a shorter arc is obtained with a little change in current level.

When changing to a different electrode wire diameter, different control settings are required. A thinner electrode wire needs more Wire speed to achieve the same current level

A satisfactory weld cannot be obtained if the Wire speed and Voltage settings are not adjusted to suit the electrode wire diameter and the dimensions of the work piece.

If the Wire speed is too high for the welding voltage, "stubbing" will occur as the wire dips into the molten pool and does not melt. Welding in these conditions normally produces a poor weld due to lack of fusion. If, however, the welding voltage is too high, large drops will form on the end of the wire, causing spatter. The correct setting of voltage and

Wire speed can be seen in the shape of the weld deposit and heard by a smooth regular arc sound. Refer to the Weld Guide located on the inside of the wire feed compartment door for setup information.

## Electrode Wire Size Selection

- The choice of Electrode wire size and shielding gas used depends on the following
- Thickness of the metal to be welded
- Capacity of the wire feed unit and Power Source
- The amount of penetration required
- The deposition rate required
- The bead profile desired
- The position of welding
- Cost of the wire

## RANGE OF WELDING CURRENT AND VOLTAGE IN CO<sub>2</sub> WELDING

Wire(mm)	Short circuit transition		Globular transition	
	Current (A)	Voltage (V)	Current (A)	Voltage (V)
0.6	40~70	17~19	160~400	25~38
0.8	60~100	18~19	200~500	26~40
1.0	80~120	18~21	200~600	27~40

### The option of the welding speed

The welding quality and productivity should be taken into consideration for the option of welding speed. In case that the welding speed increases, it weakens the protection efficiency and speeds up the cooling process. As a consequence, it is not optimal for the seaming. In the event that the speed is too slow, the work piece will be easily damaged, and the seaming is not ideal. In practical operation, the welding speed should not exceed 1m/min.

### The length of wire sticking out

The length of wire sticking out the nozzle should be appropriate. The increase of the length of wire sticking out of the nozzle can improve the productivity, but if it is too long, excessive spatter will occur in the welding process. Generally, the length of wire sticking out the nozzle should be 10 times as the welding wire diameter.

### The setting of the CO<sub>2</sub> flow volume

The protection efficiency is the primary consideration. Besides, inner-angle welding has better protection efficiency than external-angle welding. For the main parameter, refer to the following figure.

*Option of CO<sub>2</sub> flow volume*

Welding mode	Thin wire CO <sub>2</sub> welding	Thick wire CO <sub>2</sub> welding	Thick wire, big current CO <sub>2</sub> welding
CO <sub>2</sub> (L/min)	5~15	15~25	25~50

## WELDING PARAMETERS TABLE

The option of the welding current and welding voltage directly influences the welding stability, welding quality and productivity. In order to obtain the good welding quality, the welding current and welding voltage should be set optimally. Generally, the setting of weld condition should be according to the welding diameter and the melting form as well as the production requirement.

The following parameter is available for reference.

Parameter for butt-welding

Plate thickness T (mm)	Gap g(mm)	Wire $\phi$ (mm)	Welding current (A)	Welding voltage (V)	Welding speed (cm/min)	Gas volume (L/min)
0.8	0	0.8~0.9	60~70	16~16.5	50~60	10
1.0	0	0.8~0.9	75~85	17~17.5	50~60	10~15
1.2	0	1.0	70~80	17~18	45~55	10
1.6	0	1.0	80~100	18~19	45~55	10~15
2.0	0~0.5	1.0	100~110	19~20	40~55	10~15
2.3	0.5~1.0	1.0 or 1.2	110~130	19~20	50~55	10~15
3.2	1.0~1.2	1.0 or 1.2	130~150	19~21	40~50	10~15
4.5	1.2~1.5	1.2	150~170	21~23	40~50	10~15

Parameter for flat fillet welding

Plate thickness T (mm)	Gap g(mm)	Wire $\phi$ (mm)	Welding current (A)	Welding voltage (V)	Welding speed (cm/min)	Gas volume (L/min)
1.0	2.5~3.0	0.8~0.9	70~80	17~18	50~60	10~15
1.2	2.5~3.0	1.0	70~100	18~19	50~60	10~15
1.6	2.5~3.0	1.0 ~ 1.2	90~120	18~20	50~60	10~15
2.0	3.0~3.5	1.0 ~ 1.2	100~130	19~20	50~60	10~20
2.3	2.5~3.0	1.0 ~ 1.2	120~140	19~21	50~60	10~20
3.2	3.0~4.0	1.0 ~ 1.2	130~170	19~21	45~55	10~20
4.5	4.0~4.5	1.2	190~230	22~24	45~55	10~20

Parameter for fillet welding in the vertical position

Plate thickness T (mm)	Gap g(mm)	Wire $\phi$ (mm)	Welding current (A)	Welding voltage (V)	Welding speed (cm/min)	Gas volume (L/min)
1.2	2.5~3.0	1.0	70~100	18~19	50~60	10~15
1.6	2.5~3.0	1.0 ~ 1.2	90~120	18~20	50~60	10~15
2.0	3.0~3.5	1.0 ~ 1.2	100~130	19~20	50~60	10~20
2.3	3.0~3.5	1.0 ~ 1.2	120~140	19~21	50~60	10~20
3.2	3.0~4.0	1.0 ~ 1.2	130~170	22~22	45~55	10~20
4.5	4.0~4.5	1.2	200~250	23~26	45~55	10~20

Parameter for Lap Welding

Plate thickness T (mm)	Gap g(mm)	Wire $\phi$ (mm)	Welding current (A)	Welding voltage (V)	Welding speed (cm/min)	Gas volume (L/min)
0.8	A	0.8~0.9	60~70	16~17	40~45	10~15
1.2	A	1.0	80~100	18~19	45~55	10~15
1.6	A	1.0 ~ 1.2	100~120	18~20	45~55	10~15
2.0	A or B	1.0 ~ 1.2	100~130	18~20	45~55	15~20
2.3	B	1.0 ~ 1.2	120~140	19~21	45~50	15~20
3.2	B	1.0 ~ 1.2	130~160	19~22	45~50	15~20
4.5	B	1.2	150~200	21~24	40~45	15~20

## CAUTION

### 1. Working environment

1. Welding should be carried out in a relatively dry environment with its humidity of 90% or less.
2. The temperature of the working environment should be within -10°C to 40°C.
3. Avoid welding in the open air unless sheltered from sunlight and rain, and never let rain or water infiltrate the machine.
4. Avoid welding in dusty area or environment with corrosive chemical gas.
5. Avoid gas shielded arc welding in environment with strong airflow.

### 2. Safety tips

Over-current/overheating protection circuit is installed in this welding machine. If the output current is too high or overheating generated inside this welding machine, this welding machine will stop automatically. However, inappropriate use will still lead to machine damage, so please note:

#### 1. Ventilation

High current passes when welding is carried out, thus natural ventilation cannot satisfy the welding machine's cooling requirement. Maintain good ventilation of the louvers of this welding machine. The minimum distance between this welding machine and any other objects in or near the working area should be 30cm. Good ventilation is of critical importance for the normal performance and service life of this welding machine.

#### 2. No over-current.

Remember to observe the max load current at any moment (refer to the optioned duty cycle). Make sure that the welding current should not exceed the max load current.

If welding is carried out under a current which is higher than the max current, over-current protection will occur; the output voltage of the welding machine will be not stable; arc interruption will occur. In this case, please lower the current.

#### 3. No over-load.

Over-load current could obviously shorten the welding equipment's life, or even damage the machine.

A sudden halt may occur while the welding operation is carried out while this welding machine is of over-load status. Under this circumstance, it is unnecessary to restart this welding machine. Keep the built-in fan working to bring down the temperature inside the welding machine.

#### 4. Avoid electric shock.

An earth terminal is available for this welding equipment. Connect it with the earth cable to avoid the static and electric shock.

## MAINTENANCE

1. Disconnect input plug or power before maintenance or repair on machine.
2. Be sure input ground wire is properly connect to a ground terminal.
3. Check whether the inner gas-electricity connection is well (esp. the plugs), and tighten the loose connection; if there is oxidization, remove it with sand paper and then re-connect.
4. Keep hands, hair, loose clothing, and tools away from electrical parts such as fans, wires when the machine is switched on.
5. Clear the dust at regular intervals with clean and dry compressed air; if the working condition is with heavy smoke and air pollution, the welding machine should be cleaned daily.
6. The compressed air should be reduced to the required pressure so that small components inside the machine will not be damaged.
7. To avoid water and rain, if there is, dry it in time, and check the insulation with mega-meter (including that between the connection and that between the case and the connection). Only when there is no abnormal phenomenon should the welding continue.
8. If the machine is not used for a long time, put it into the original packing in dry condition.



## DAILY CHECKS

To make best use of the machine, daily checking is very important. During the daily checking, please check in the order of torch, wire-feeding vehicle, all kinds of PCB, the gas hole, and so on. Remove the dust or replace some parts if necessary. To maintain the purity of the machine, please use original welding parts.

**CAUTIONS:** Only the qualified technicians are authorized to undertake the repair and check task of this welding equipment in case of machine fault.

### 11.1. Power supply

Part	Check	Remarks
Control panel	1. Operation, replacement and installation of Switch.	
	2. Switch on the power, and check if the power indicator is on.	
Fan	1. Check if the fan is functioning and the sound generated is normal.	If the fan doesn't work or the sound is abnormal, do inner check.
Power supply	1. Switch on the power supply, and check if abnormal vibration, heating of the case of this equipment, variation of colors of case or buzz presents.	
Other parts	1. Check if gas connection is available, case and other joints are in good connection.	

### 11.2. Welding torch

Part	Check	Remarks
Nozzle	1. Check if the nozzle is fixed firmly and distortion of the tip exists.	Possible gas leakage occurs due to the unfixed nozzle.
	2. Check if there is spatter sticking on the nozzle.	Spatter possibly leads to the damage of torch. Use anti-spatter to eliminate the spatter.
Contact tip	1. Check if the contact tip is fixed firmly.	Unfixed contract tip possibly leads to unstable arc.
	2. Check if the contact tip is physically complete.	The physically incomplete contact tip possibly leads to unstable arc and arc automatically terminating.
Wire feeding hose	1. Make sure that there is the agreement of wire and wire feed tube.	Disagreement of the diameters of wire and wire feed tube possibly leads to the unstable arc. Replace it/them if necessary.
	2. Make sure that there is no bending or elongation of wire feed tube.	Bending and elongation of wire feed tube possibly leads to the unstable wire feed and arc. Replace it if necessary.
	3. Make sure that there is no dust or spatter accumulated inside the wire feed tube, which makes the wire feed tub blocked.	If there is dust or spatter, remove it.
	4. Check if the wire feed tube and O-shaped seal ring are physically complete.	The Physically incomplete wire feed tube or O-shaped seal ring possibly leads to the excessive spatter. Replace the wire feed tube or O-shaped seal ring if necessary.
Diffuser	Make sure that the diffuser of required specification is installed and is unblocked.	Defection weld or even the damage of torch occurs due to the non-installation of diffuser or the unqualified diffuser.

## 11.3. Wire feeder

Part	Check	Remarks
Pressure adjusting handle	1. Check if the pressure-adjusting handle is fixed and adjusted to the desired position.	The unfixed pressure-adjusting handle leads to the unstable welding output.
Wire-feeding hose	1. Check if there is dust or spatter inside the hose or beside wire-feeding wheel.	Remove the dust.
	2. Check if there is a diameter agreement of wire and wire-feeding hose.	Non-agreement of the diameter of wire and wire-feeding hose possibly leads to the excessive spatter and unstable arc.
	3. Check if rod and wire feeding groove are concentric.	Unstable arc possibly occurs.
Wire-feeding wheel	1. Check if there is an agreement of wire diameter and wire-feeding wheel.	Non-agreement of wire diameter and wire-feeding wheel possibly leads to the excessive spatter and unstable arc.
	2. Check if the wire groove is blocked.	Replace it if necessary.
Pressure adjusting wheel	1. Check if the pressure adjusting wheel can rotate smoothly, and it's physically complete.	Unstable rotation or physical incompleteness of the wheel possibly leads to unstable wire feeding and arc.

## 11.4. Cables

Part	Check	Remarks
Torch cable	1. Check if the cable of torch is twisted.	The twisted torch cable leads to unstable wire feeding and arc.
	2. Check if the coupling plug is in loose connection.	
Output cable	1. Check if the cable is physically complete.	Relevant measures should be taken to obtain stable weld and prevent the possible electric shock.
	2. Check if insulation damage or loose connection exists.	
Input cable	1. Check if the cable is physically complete.	
	2. Check if insulation damage or loose connection exists.	
Earth cable	1. Check if the earth cables are well fixed and not short-circuited.	Relevant measures should be taken to prevent the possible electric shock.
	2. Check if this welding equipment is well grounded.	

## CONNECTION DIAGRAM OF THE MACHINE

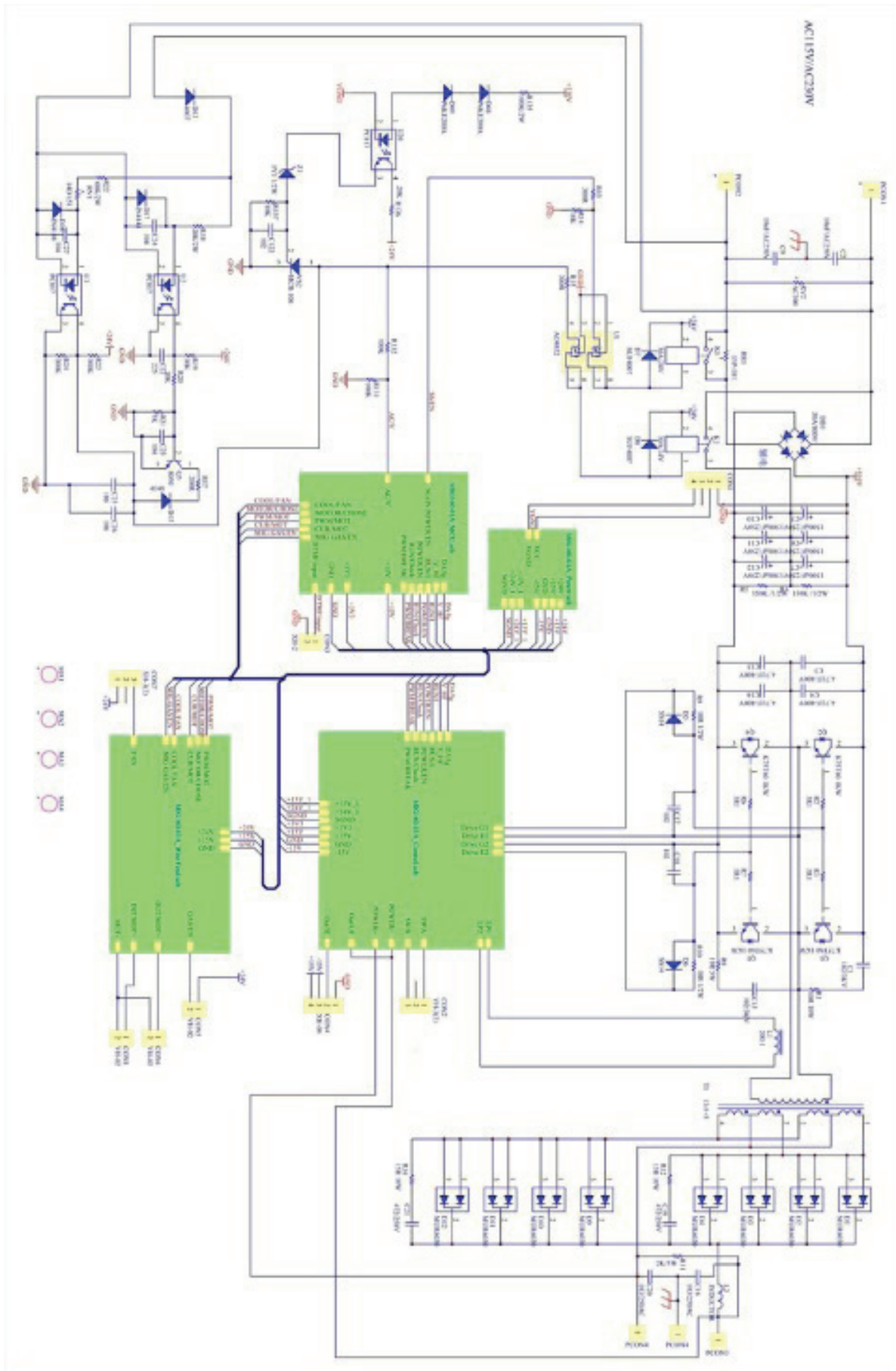

## EXPLODED DRAWING

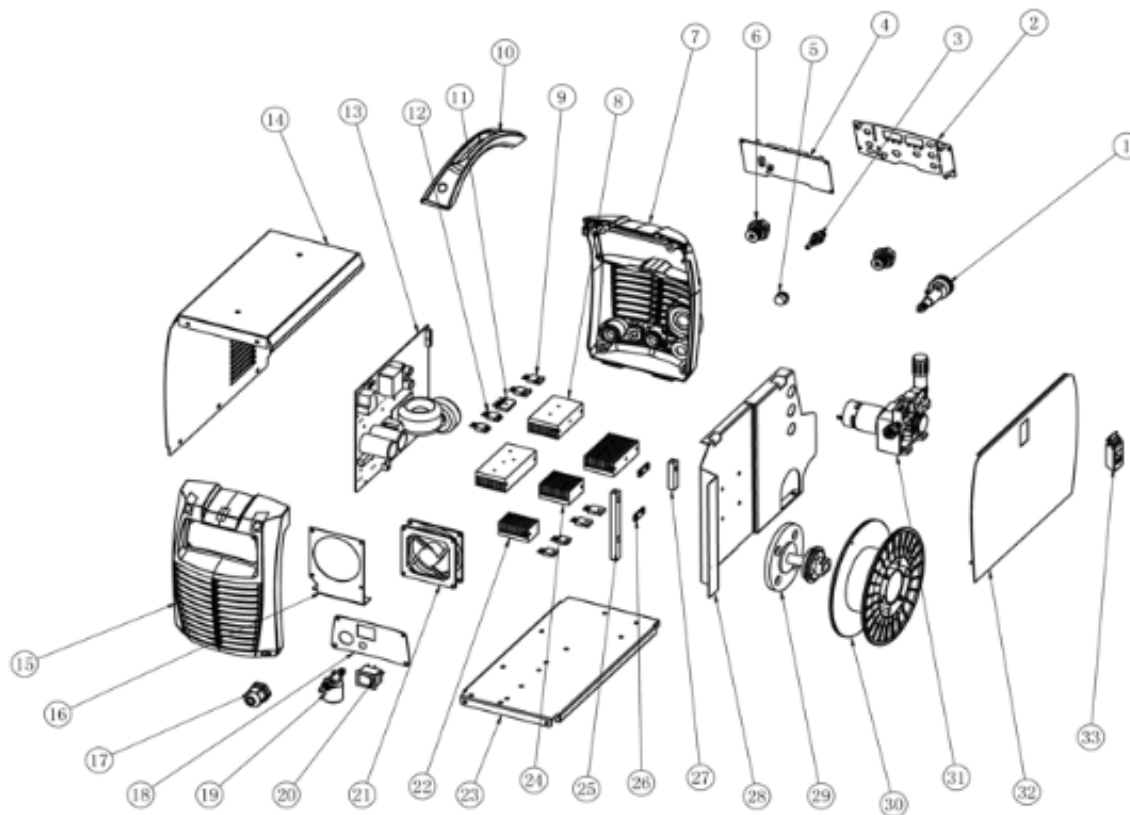

NO	NAME	NO	NAME
1	Euro type MIG torch socket	18	rear panel
2	front panel	19	solenoid valve
3	input quick connector	20	power switch
4	control PCB	21	fan
5	aviation socket	22	radiator 2
6	output quick connector	23	base panel
7	front plastic cover	24	radiator 3
8	radiator 1	25	metal stand 1
9	rectifier tube	26	support parts
10	handle	27	metal stand 2
11	rectifier bridge	28	clapboard
12	IGBT	29	wire spool
13	main PCB	30	wire spool holder
14	casing	31	wire feeder
15	rear plastic cover	32	side plate
16	fan fixer	33	lock
17	wire clip	34	

## WARRANTY

### Duralloy Welding Equipment

#### 1 YEAR WARRANTY\*

Duralloy Industrial Supply warrants the original retail purchaser that the Duralloy Welding and Cutting machines purchased will be free from defects in materials and workmanship for a period of 1 years\* from the date of purchase by the customer. If a defect in material or workmanship becomes evident during this period, Duralloy Industrial Supply will at its option;

- Repair the product (or pay for the repair of the product)
- Replace the product

In case of warranty claim the product should be returned to the original place of purchase, with proof of purchase.

Any handling and transport costs (or other expenses) incurred in claiming warranty are not covered by this warranty. The warranty schedule is:

- Duralloy Power source only\* - 1 year
- Duralloy Regulator - 3 months
- MIG Torches - 3 months
- TIG Torches - 3 months
- Plasma Torches - 3 months
- Ancillary Equipment - 3 months

The Obligation of Duralloy Industrial Supply under this warranty is limited to the circumstance set out above and is subject to:

- The customer being able to provide proof of purchase of the relevant equipment.
- A defect in either material or workmanship.
- The customer returning the product to Duralloy Industrial supply or an authorized repair agent.
- The product not having been altered or tampered with.
- The product not having been used outside the normal operating parameters of this equipment.
- The product to be in good condition and not damaged which may cause a fault

All goods come with a guarantee that cannot be excluded under the Australian Consumer laws. You as a consumer are entitled to a replacement or a refund for a major failure. You are also entitled to have the goods repaired or replaced if the products fail to be of acceptable quality:

This Warranty Provided by:

Duralloy Industrial Supply - (ABN - 81 831 839 268)

2 Hollylea Road Leumeah NSW 2560

1300 369 456

**DURALLOY®**