

**DURALLOY®**

# **CUT 40 PFC MV**

## **OWNER'S MANUAL**



## **Congratulations on your new DURALLOY® product!**

The DURALLOY range uses latest technology design and engineering to produce welding products that combine market leading value and features with durability. Designed for discerning operators who seek professional results and product quality without the price tag of a full professional setup. Design emphasis is placed on simple, functional design and operation. DURALLOY product is subject to stringent quality control and designed and manufactured to EN60974-1.2012 standards.

Common use of DURALLOY products include:

- Light Engineering
- Automotive
- Home / Hobby Engineering
- Farming
- Industrial Maintenance & Repairs

For industrial welding solutions, check out the DURALLOY at [www.duralloy.net.au](http://www.duralloy.net.au)

DURALLOY is a market leading provider of innovative power equipment solutions to a wide range of industries across Australia. Key product categories are; welding equipment, power generators and cleaning equipment.

## **CONTENTS**

Know Your Machine	5
Quick Start Guide	7
Wiring Diagram	8
Care & Maintenance	9
Troubleshooting	12
Safety	13
Warranty	18

# CUT 40PFC MV

240V Inverter Plasma Cutter

PART NO: **DACUT40P**



PLASMA



7KG

EN60974-1:2012



3 YEAR WARRANTY



## PFC TECHNOLOGY

Most DURALLOY® Welding Machines feature PFC Technology for maximum electrical efficiency and consistent weld output.

## PILOT ARC CONTROLLER

Increases cutting capabilities and speed. Extends tip's life. Ideal for grid cutting.

## PROTECTIONS

Equipped with temperature, voltage and current sensors for greater protection.

## GENERATOR FRIENDLY

Designed to work from power generators (8.5kva).

## COMPRESSOR REQUIREMENT

- 12cfm Compressor
- 4 bar (60PSI)

## FEATURES

- Wide input voltage - 90VAC - 275VAC
- Generator friendly (8.5kVA)
- High Duty Cycle -30 Amps @ 100%
- IP23 Rating
- Protective Front Fascia Cover
- Air Test function
- 6M PT60 Plasma Torch with Central Adaptor
- Built-in Regulator
- Extension lead friendly up to 100m
- Weight 7kg

## SPECIFICATIONS

Power Supply	90VAC - 275VAC	
Supply Plug	15 Amps	
Frequency	50/60Hz	
	1-110/120/130V ± 10%	1-220/230/240V ± 10%
Input Power	3.8kW	4.9kW
Input Current	34.5A	22.6A
Duty Cycle	30A 35%	40A 50%
40°C 10min	22A 60%	36A 60%
	20A 100%	30A 100%
Cutting Current	20 - 30A	20 - 40A
Severance Cut for Carbon Steel	≤ 20mm	≤ 25mm
Production Cut		
• Carbon Steel	≤ 15mm	≤ 20mm
• Stainless Steel	≤ 15mm	≤ 20mm
• Aluminium	≤ 12mm	≤ 16mm
• Copper	≤ 8mm	≤ 12mm
Net Weight	7kg	
Dimensions	480mm x 146mm x 278mm	
Insulation Class	H	
Protection Class	IP23	
Cooling	Auto Fan	
Power Factor	0.99	

## APPLICATIONS

- Boat Building
- General Fabrication
- Automotive Crash Repair
- Aluminium Fabrication
- Stainless Fabrication
- On-site Fabrication

## MATERIALS

- Mild Steel
- Aluminium
- Stainless Steel

## PACKAGE INCLUDES

- Power Source
- 6M PT60 Plasma Torch
- 3M Earth
- Owner's Manual

## KNOW YOUR MACHINE

More detailed explanations of function on following pages.

1. Cutting Current Control Knob.
2. Power Indicator. Lights when input power connected and machine switched on
3. Power Error/ Overload Indicator\*
4. Torch System Error Indicator\*
5. Cutting Power Indicator. Lights when cutting power circuit activated
6. Air Control Run/ Set Switch \*
7. Earth Lead Connection Socket.
8. Plasma Torch Euro/ Central Connector

### Rear View

9. Air Pressure Regulator Outlet Pressure Gauge
10. Air Pressure Regulator Knob
11. Compressed Air Inlet
12. Air Condensate Filter/ Trap Bowl
13. Air Filter Condensate Drain Tube



## FURTHER CONTROLS EXPLAINED

### Overload/ Error Indicator (3)

Lights when over voltage, over current or electrical overheating (due to exceeding duty cycle) is detected and protection is activated.

When protection is activated, welding output will be disabled until the safety system senses the overload has reduced sufficiently and indicator lamp goes out. May also trigger if machine experiences an internal power circuit failure.

### Torch System Error Indicator (4)

Lights when issue with torch system or air supply detected and cutting output is disabled as a result. Flashing light means that torch shield cap is not installed. Continuous light means likely damaged or missing torch consumables or insufficient air pressure supply to the torch.

### Compressed Air Testing/Setting Switch (6)

When positioned as 'set' compressed air control valve is open continuously. This is useful for testing and setting the air pressure without having to activate the trigger circuit. 'Run' position is normal operation.

## TIPS & TRICKS

### Air Regulator Pressure Adjustment

Correct air pressure is critical for plasma cutting. Incorrect air pressure will cause poor cut quality, lack of cutting power, damage to the plasma torch and consumables and potentially damage the power source. Optimum air pressure is between 0.45 and 0.5 MPa (65-75psi). Air pressure should be set with the air flowing through the torch, as the pressure with the air flowing will normally be less than static pressure, due to flow losses through the torch system. To unlock the pressure regulator knob in order to adjust it, pull the knob upwards. Once the pressure is set correctly, push the knob down again to lock it into place.

### Air Filter/ Water Separator

As with correct air pressure, clean, dry air is also critical for plasma cutting machine performance and reliability. The DURALLOY CUT 40PFC MV is supplied with an air filtration/ moisture separator to assist with providing suitable air supply. The moisture separator is self-draining, the water drain tube exits out the bottom of the clear condensate bowl. It is normal to see moisture coming from this tube periodically. If excessive amounts of water or oil are being produced in the condensate bowl and drain line, the compressed air supply should be checked for issues.

### Pilot Arc System

The DURALLOY CUT 40PFC MV use a pilot arc system to establish the main cutting arc. A pilot arc system is a circuit where the return is back through the torch head and cable. This means it can create a small arc with some cutting power without making any electrical connection with the main machine earth. This is especially useful for starting cuts on material that does not have a good initial earth connection, such as paint, rust, scale.

Once the pilot arc is established and power is flowing back through the main earth, the pilot arc is switched off and the main arc started. Please note the pilot arc circuit is only designed to operate for short periods of time as an auxiliary starting system, so it has a safety protection that only allows the pilot arc to run for short periods at a time. In addition to this, these models also have a pilot arc controller system if the main arc cuts out and the torch remains to be triggered, the pilot arc will reignite. This is useful for cutting discontinuous workpieces like mesh or grids.

It is very important to recognise that plasma torch consumables wear as part of normal operation and should be replaced in a timely manner. Operating a torch with worn consumables will cause poor cutting results and possible damage to the torch and machine itself. Damage caused by untimely replacement of consumables will not be covered by warranty.

Use the following guidelines to determine when consumables should be replaced:

**Cutting Tips:** The cutting tip has a small calibrated orifice that the plasma passes through. If the orifice becomes partially blocked, deformed or enlarged, the cutting tip should be replaced.

**Electrodes:** The electrode has a small silver 'hafnium' insert in the end of the tip. This is what generates the plasma ions. Once the hafnium insert is gone or is damaged the tip must be replaced.

**Swirl Ring/Retaining Cap:** These should be replaced if broken, chipped, cracked or badly heat damaged.

**Tips and electrodes:** These should wear reasonably evenly and it is normal practice to replace them both together. If a new tip is inserted with a worn electrode the tip will wear much more quickly than if the electrode was also replaced at that same time. If tips or electrodes are wearing much faster than the other component it is likely to be caused by one of the following: poor operator technique, incorrect air supply or damaged torch head.

It is also very important to only use genuine DURALLOY consumables and parts for the SC60 torch. They are engineered to suit the machine and non-genuine items may cause lack of performance, short life span, torch and machine damage and void warranty.

## Duty Cycle Rating

Cutting duty cycle is the percentage of actual cutting time that can occur in a ten minute cycle. E.g. 20% at 40 amps - this means the plasma cutter can operate at 40 amps for 2 minutes and then the unit will need to be rested for 8 minutes. All duty cycle ratings are based on an ambient air temperature of 40°C with 50% humidity, which is the international standard for such a rating. In an environment with temperatures exceeding 40°C, the duty cycle will be less than stated. In ambient temperature less than 40°C, duty cycle performance will be higher.

## QUICK START GUIDE PLASMA CUTTER INSTALLATION

### Electrical Connection

The DURALLOY CUT 40PFC MV are designed to operate on a 15A 230V AC power supply.

The AdvanceCut Multivoltage technology allows the machine to operate on a very wide range input voltages down as low as 90V. This means that limited capacity power supplies and long extension leads may be used without damaging the plasma cutter.

However, as the supply voltage decreases, the maximum output current and duty cycle will also decrease. To utilise the full output capacity of the machine using an extension cord, it should be a heavy duty version with a minimum cable core size of 2.5mm<sup>2</sup>. It is recommended to use an industrial duty 15A extension lead.

### Compressed Air Requirements

A reliable and consistent supply of clean dry compressed air is essential for proper operation. Although the machine contains its own internal air supply filtration system it is recommended the compressed air supply should have external filtration in the line feeding the machine, both a standard water trap (sintered bronze filter) and also a coalescing filter (for oil in air). The air requirement is a minimum of 120 l/min (4.5cfm) Free Air Delivery (FAD) at 75psi pressure. This normally means the compressor must be a belt drive model or if a direct drive it must have a motor power of 2.5HP or greater.

The air must be dry and free of oil and moisture (normally a symptom of older, worn out compressors). The air hose must also be of sufficient size (3/8"/10mm minimum) to supply the machine

### Operating Environment

Adequate ventilation is required to provide proper cooling for the DURALLOY CUT 40PFC MV. Ensure that the machine is placed on a stable level surface where clean cool air can easily flow through the unit. The has electrical components and control circuit boards which may be damaged by excessive dust and dirt, so a clean operating environment is important for reliable product life.

## BASIC OPERATION

- 1.1 Connect the earth cable quick connector to the earth connection socket (7) Connect the earth clamp to the work piece. Contact with the work piece must be firm contact with clean, bare metal, with no corrosion, paint or scale at the contact point.
- 1.2 Connect the plasma torch to the machine central connector (8) ensuring the collar is done up firmly.
- 1.3 Connect the machine to suitable mains power using the mains input power lead. Switch the mains power switch to 'on' to power up the machine.
- 1.4 Connect the compressed air supply to the filter/ regulator inlet (11). Check the air pressure (10). Trigger the air flow using the 'set' function (6), check the air pressure again and adjust if necessary. Return the switch to 'run' position.
- 1.4 Select the output current using the current control knob (1). You are now ready to plasma cut!

**WIRING DIAGRAM**

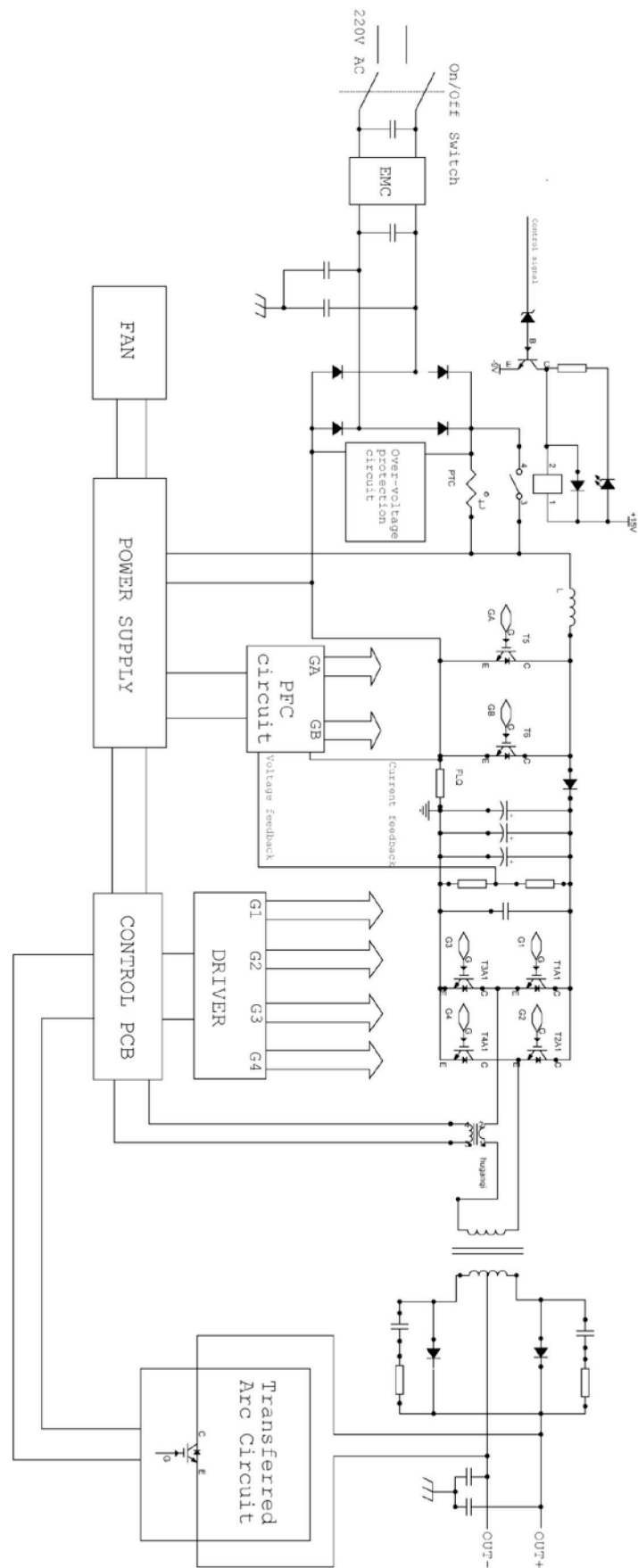



## CARE & MAINTENANCE

### Keep your plasma cutter in top condition

The DURALLOY CUT 40PFC MV does not require any special maintenance, however the user should take care of the machine as follows:

- Regularly clean the ventilation slots.
- Keep the casing clean.
- Check all cables before use.
- Check work leads/clamps and torches before use.
- Replace worn earth clamps that do not provide a good connection.
- Replace worn consumable parts in a timely manner.
- Use a soft cloth or brush to clean electrical components.
- Do not use liquid cleaning products, water or especially solvents.
- Do not use compressed air to clean electrical components as this can force dirt and dust further into components, causing electrical short circuits.
- Check for damaged parts. Do not use the plasma cutter with damaged parts.
- A damaged plasma cutter must be carefully checked by a qualified person to determine that it will operate properly. Check for breakage of parts, mountings and other conditions that may affect its operation. An authorised service centre should properly repair a damaged part. Have your machine repaired by an expert.

This appliance is manufactured in accordance with relevant safety standards. Only experts must carry out repairing of electrical appliances, otherwise considerable danger for the user may result. Use only genuine replacement parts. Do not use modified or non-genuine parts.

### Storing the Plasma Cutter

When not in use the plasma cutter should be stored in the dry and frost-free environment.



#### WARNING!

Before performing cleaning/maintenance, replacing cables / connections, make sure the welding machine is switched off and disconnected from the power supply.

## PLASMA CUTTING GUIDE

### Cutting Guide

#### Effect of Cutting Speed

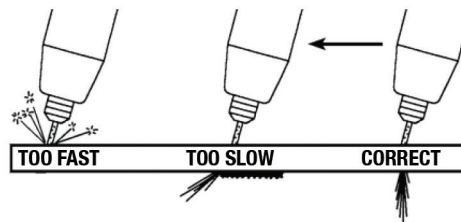

### Electrical Connection

The DURALLOY CUT 40PFC MV is designed to run on a standard 15A 230V AC power supply. If an extension cord must be used, it should be no longer than 10m and be a heavy duty industrial 15A version with a minimum cable core of 2.5mm<sup>2</sup>.

### Operating Environment

Adequate ventilation is required to provide proper cooling for the DURALLOY CUT 40PFC MV. Ensure that the machine is placed on a stable level surface where clean cool air can easily flow across the unit. The DURALLOY CUT 40PFC MV has electrical components and control circuit boards which will be damaged by excessive dust and dirt, so a clean operating environment is essential.

### Compressed Air Requirements

A reliable and consistent supply of clean dry compressed air is essential for proper operation of the DURALLOY CUT 40PFC MV. Although the machine contains its own filtration system, it is recommended the compressed air supply have external filtration in the line feeding the DURALLOY CUT 40PFC, both a standard water trap (sintered bronze filter) and, a coalescing filter (for oil in air). The DURALLOY CUT 40PFC requires a minimum of 120 L/min (4.5cfm) Free Air Delivery (FAD) at 75psi pressure.

This normally means the compressor must be a belt drive model or if a direct drive, must have a motor power of 2.5HP or greater.

The air must be dry and free of oil and moisture (normally a symptom of older, worn out compressors). The air hose must also be of sufficient size (3/8"/10mm minimum) to supply the machine.

## CUTTING WITH THE DURALLOY CUT40 PFC MV

After turning the Power Switch (12) to the ON position and making control and air pressure adjustments, proceed as follows:

1. Hold the tip of the Torch within 3-4mm the work piece, at about 15- 30° angle to avoid damaging the tip.
2. Depress the torch switch. (Air and the high frequency spark should energize)
3. As the high frequency spark jumps to the work piece, the main plasma arc will ignite and start cutting.
4. After starting the cut, the tip can be dragged along the work piece if cutting up to 3mm thick material. When cutting material greater than 3mm, maintain a 3.2mm tip-to-work (standoff) distance.
5. When ending a cut, the torch switch should be released and lifted off the work piece just before the end of the cut to minimize double-arcing which can damage the tip. This is to prevent the high frequency arc starting from reigniting after cutting arc extinguishes.
6. In the post-flow mode, the arc can be restarted immediately by depressing the torch switch.

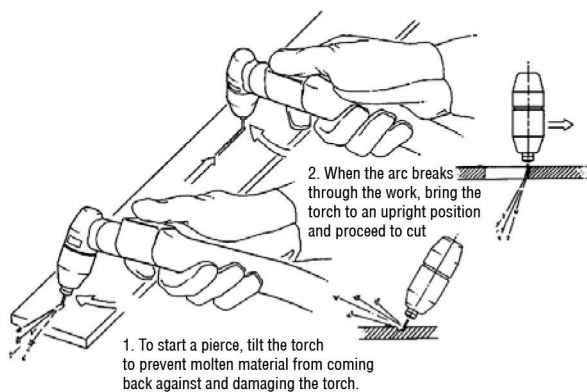

*NOTE: Keep moving while cutting. Cut at a steady speed without pausing. Maintain the cutting speed so that the arc lag is 10° to 20° behind the travel direction. Use a 5° - 15° leading angle in the direction of the cut.*

## OPERATING TECHNIQUES

1. **Piercing** - Materials (up to 3.2mm/1/8in. thick) may be pierced with the torch touching the work. When piercing thicker materials (up to 4.8mm stainless or carbon steel) at an angle, position the torch 0.5mm (.02") above the work piece.  
It is advisable when piercing thicker materials to drill a small pilot/starting hole in the work piece which makes it a lot easier and gives increased tip life. Start the cutting arc, then immediately raise the torch to 1.6mm (1/16") stand-off and move the torch along the cut path. This will reduce the chance of spatter from entering the torch and prevent the possibility of welding the tip to the plate. The torch should be angled at about 30° when starting to pierce, and then straightened after accomplishing the pierce.
2. **Grate Cutting** - For rapid restarts, such as grate or heavy mesh cutting, do not release the torch switch. This avoids the 2 second pre-flow portion of the cutting cycle.
3. **Edge Starting** - For edge starts, hold the torch perpendicular to the work piece with the front of the tip near (not touching) the edge of the work piece at the point where the cut is to start. When starting at the edge of the plate, do not pause at the edge and force the arc to 'reach' for the edge of the metal.

CUTTING SPEED GUIDE		
Material	Thickness (mm)	Cutting Speed (mm/s)
Carbon Steel (AISI 1020)	1.6	150
	3.2	50
	6.4	20
Stainless Steel (AISI 304)	1.6	140
	3.2	40
	6.4	15
Aluminium (6061)	1.6	190
	3.2	85
	6.4	30

*Note: The speeds given here are typical for best quality cuts. Your actual speeds may vary depending on material composition, surface condition, operator technique, etc. If cutting speed is too fast, you may lose the cut. With slower speeds excessive dross may accumulate. If speed is too slow, the arc may extinguish. Air cutting typically produces a rough face on stainless steel and aluminium.*

## ESTABLISH THE CUTTING ARC AS QUICKLY AS POSSIBLE.

4. **Drag Cutting** - Position torch tip slightly above work piece, press torch switch and lower torch tip forward work piece until contact is made and cutting arc is established. After cutting arc is established, move the torch in the desired direction keeping the torch tip slightly angled, maintaining contact with the work piece. Avoid moving too fast as would be indicated by sparks radiating from the topside of the work piece. Move the torch just fast enough to maintain sparks concentration at the underside of the work piece and making sure the material is completely cut through before moving on. Adjust drag speed as desired/ required.
5. **Direction of Cut** - The plasma gas stream swirls as it leaves the torch to maintain a smooth column of gas. This swirl effect results in one side of a cut being more square than the other. Viewed along the direction of travel, the right side of the cut is more square than the left.
6. **Quality Cuts** – Dross (slag) is the excess material that spatters and builds up on the underside of the work-piece as you cut. Dross occurs when the operating procedure and technique is less than optimal. It will require practice and experience to obtain cuts without dross. Although less than optimal cuts will contain dross, it is relatively easy to remove by breaking it off using pliers or chipping off with a chisel or scraping or grinding the finished cut as needed and is generally only a minor inconvenience.

A combination of factors contributes to the build-up of dross. They include; material type, material thickness , amperage used for the cut, speed of the torch across the work-piece, condition of the torch tip, input line voltage, air pressure, etc. Generally there is an inversely proportional relationship between output current and speed of cut. Do not use more output current than is necessary and adjust speed of cut toward minimizing dross build-up on underside of cut. Experiment with adjusting current and speed to minimize dross.

When dross is present on carbon steel, it is commonly referred to as either 'high speed, slow speed, or top dross'. Dross present on top of the plate is normally caused by too great a torch to plate distance.

'Top dross' is normally very easy to remove and can often be wiped off with a welding glove. 'Slow speed dross' is normally present on the bottom edge of the plate. It can vary from a light to heavy bead, but does not adhere tightly to the cut edge, and can be easily scraped off. 'High speed dross' usually forms a narrow bead along the bottom of the cut edge and is very difficult to remove. When cutting troublesome steel, it is sometimes useful to reduce the cutting speed to produce 'slow speed dross'. Any resultant clean up can be accomplished by scraping, not grinding.

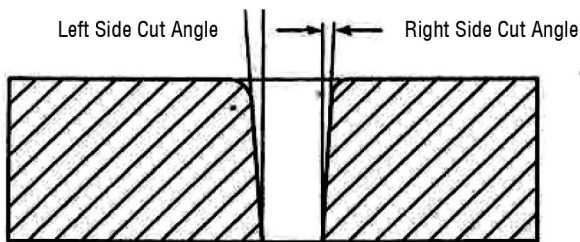

*To make a square-edged cut along an inside diameter of a circle, the torch should move counter clockwise around the circle. To keep the square edge along an outside diameter cut, the torch should travel in a clockwise direction.*

## TROUBLESHOOTING

PROBLEM	CAUSE	SOLUTION
Torch will not come on	<ul style="list-style-type: none"> <li>Power switch OFF</li> <li>Air supply is not of sufficient volume or pressure</li> <li>Work piece ground clamp not attached.</li> </ul>	<ul style="list-style-type: none"> <li>Turn power switch to the ON position</li> <li>Check air supply (60–80 PSI, 3.5cfm required)</li> <li>Attach to work piece or to steel table with work piece securely clamped to table</li> </ul>
Sparks are shooting upward instead of down through the material.	<ul style="list-style-type: none"> <li>Plasma torch is not piercing the material</li> <li>Torch may be too far away from the workpiece</li> <li>Material may not be earthed properly</li> <li>Travel speed too fast</li> </ul>	<ul style="list-style-type: none"> <li>Increase current</li> <li>Decrease the distance of your torch to the workpiece</li> <li>Check connections for proper earth</li> <li>Reduce speed</li> </ul>
Beginning of cut not completely pierced	<ul style="list-style-type: none"> <li>Possible earth connection problem</li> </ul>	<ul style="list-style-type: none"> <li>Check all connections</li> </ul>
Dross build-up on parts of cuts	<ul style="list-style-type: none"> <li>Tool/material building up heat</li> <li>Cutting speed too slow or current too high</li> <li>Worn torch parts</li> </ul>	<ul style="list-style-type: none"> <li>Allow material to cool then continue cut.</li> <li>Increase speed and/or reduce current until dross is reduced to minimum</li> <li>Inspect and repair or replace worn parts</li> </ul>
Arc stops while cutting	<ul style="list-style-type: none"> <li>Cutting speed too slow</li> <li>Torch is too high, away from material</li> <li>Worn torch parts</li> <li>Workpiece earth cable disconnected</li> </ul>	<ul style="list-style-type: none"> <li>Increase speed until problem solved</li> <li>Lower torch to recommended height</li> <li>Inspect and repair or replace worn parts</li> <li>Connect workpiece earth clamp to work piece or steel table.</li> </ul>
Insufficient penetration	<ul style="list-style-type: none"> <li>Cutting speed too fast</li> <li>Torch tilted too much</li> <li>Metal too thick for plasma capacity</li> <li>Worn torch parts</li> </ul>	<ul style="list-style-type: none"> <li>Slow down travel speed</li> <li>Adjust tilt</li> <li>Several passes may be necessary</li> <li>Inspect and repair or replace worn parts</li> </ul>
Arc sputters/flares	<ul style="list-style-type: none"> <li>Water in the air supply</li> </ul>	<ul style="list-style-type: none"> <li>Install air drier or additional filtration</li> </ul>
Consumables wear quickly	<ul style="list-style-type: none"> <li>Exceeding unit capability</li> <li>Excessive ARC starting HF use</li> <li>Improperly assembled torch</li> <li>Inadequate air supply, pressure too low</li> <li>Faulty air compressor</li> </ul>	<ul style="list-style-type: none"> <li>Material too thick, increase angle to prevent blow back into torch tip</li> <li>Do not operate HF ARC starting for more than 3 seconds - you can also start with torch in contact with metal or within 1/16" of metal</li> <li>See section 'Replacing Consumables'</li> <li>Check air filters, increase air pressure</li> <li>Check air compressor operation and make sure input air pressure is at least 100 PSI</li> </ul>
Circuit breaker/fuse trips while operating	<ul style="list-style-type: none"> <li>Extension cord being used is not heavy duty</li> </ul>	<ul style="list-style-type: none"> <li>Use a heavy duty extension cord (2.5mm diameter)</li> </ul>

## SAFETY

### Store and Retain this Manual

Retain this manual for the safety warnings and precautions, assembly, operating, inspection, maintenance and cleaning procedures. Write the product serial number at the rear of this manual and keep this manual and the receipt in a safe and dry place for future reference.

### Important Safety Information

Failure to follow the warnings and instructions may result in electric shock, fire, serious injury and/or death. Save all warnings and instructions for future reference.



This is the safety alert symbol to alert you to potential personal injury hazards. Obey all safety messages that follow this symbol to avoid possible injury or death.

 **DANGER!**  
Indicates a hazardous situation which, if not avoided, will result in death or serious injury.

 **WARNING!**  
Indicates a hazardous situation which, if not avoided, could result in death or serious injury.

 **CAUTION**  
Used with the safety alert symbol, indicates a hazardous situation which, if not avoided, could result in minor or moderate injury.

**NOTE:** used to address practices not related to personal injury.

### General Safety Warnings

1. **Maintain labels and nameplates on the plasma cutter.** These carry important information. If unreadable or missing, contact DURALLOY for a replacement.
2. **Avoid unintentional starting.** Make sure the plasma cutter is setup correctly and you are prepared to begin work before turning on the plasma cutter.
3. **Unplug before performing maintenance.** Always unplug the plasma cutter from its electrical outlet before performing any inspection, maintenance, or cleaning procedures.

4. **Never leave the plasma cutter unattended while energised.**  
Turn power off before leaving the plasma cutter unattended.
5. **Do not touch live electrical parts.** Wear dry, insulating gloves. Do not touch the electrode or the conductor tong with bare hands. Do not wear wet or damaged gloves.
6. **Protect yourself from electric shock.** Do not use the plasma cutter outdoors. Insulate yourself from the work piece and the ground. Use non-flammable, dry insulating material if possible, or use dry rubber mats, dry wood or plywood, or other dry insulating material large enough to cover the area of contact with the work or the ground.
7. **Avoid inhaling dust.** Some dust created by power sanding, sawing, grinding, drilling, cutting, welding and other construction activities, contain chemicals known to cause cancer, birth defects or other harm. Your risk from these exposures varies, depending on how often you do this type of work. To reduce your exposure to these chemicals, work in a well-ventilated area, and work with approved safety equipment, such as dust masks that are specially designed to filter out microscopic particles.
8. **People with pacemakers should consult their physician(s) before using this machine.**

 **WARNING!**  
Electromagnetic fields in close proximity to a heart pacemaker could cause interference, or failure of the pacemaker. The use of a plasma cutter is **NOT RECOMMENDED** for pacemaker wearers. Consult your doctor.

9. **Ensure that the unit is placed on a stable location before use.**

 **WARNING!**  
If this unit falls while plugged in, severe injury, electric shock, or fire may result.

10. **Transportation Methods** Lift unit with the handles provided, or use a handcart or similar device of adequate capacity. If using a fork lift vehicle, secure the unit to a skid before transporting.

 **CAUTION**  
Disconnect input power conductors from deenergized supply line before moving the welding power source.

11. **Exercise good work practices.** The warnings, precautions, and instructions discussed in this instruction manual cannot cover all possible conditions and situations that may occur. It must be understood by the operator that common sense and caution are factors which cannot be built into this product, but must be considered by the operator.

## Plasma Cutter Safety Instructions & Warnings



### WARNING!

Protect yourself and others from possible serious injury or death. Keep children away. Read the operating/Instruction manual before installing, operating or servicing this equipment. Have all installation, operation, maintenance, and repair work performed by qualified people.

If an operator does not strictly observe all safety rules and take precautionary actions, Plasma Cutter products and processes can cause serious injury or death, or damage to other equipment or property.

Safe practices have developed from past experience in the use of welding and cutting. These practices must be learned through study and training before using this equipment. Some of these practices apply to equipment connected to power lines; other practices apply to engine driven equipment.

Anyone not having extensive training in welding and cutting practices should not attempt to use these machines.

Safe practices are outlined in the European Standard EN60974-1 entitled: Safety in welding and allied processes.



### WARNING!

Only use safety equipment that has been approved by an appropriate standards agency. Unapproved safety equipment may not provide adequate protection. Eye and breathing protection must be AS/NZS compliant for the specific hazards in the work area.



### DANGER!

Always wear AS/NZS compliant safety glasses and full face shield fitted with appropriate filter shade number. (Refer Filter Table in this safety section)



### CAUTION

Heavy-duty work gloves, non-skid safety shoes and hearing protection used for appropriate conditions will reduce personal injuries.



### CAUTION

Have the equipment serviced by a qualified repair person using identical replacement parts. This will ensure that the safety of the power tool is maintained.

## Personal Safety



### CAUTION

Keep the work area well lit. Make sure there is adequate space surrounding the work area. Always keep the work area free of obstructions, grease, oil, trash, and other debris. Do not use equipment in areas near flammable chemicals, dust, and vapours. Do not use this product in a damp or wet location.

1. Stay alert, watch what you are doing and use common sense when operating equipment. Do not use a tool while you are tired or under the influence of drugs, alcohol or medication. A moment of distraction when operating equipment may result in serious personal injury.
2. Do not overreach. Keep proper footing and balance at all times. This enables better control of the power tool in unexpected situations.

## Arc Rays can Burn Eyes and Skin



### DANGER!

Arc rays from the welding process produce intense heat and strong ultraviolet rays that can burn eyes and skin.

1. Use a Welding Helmet or Welding Face Shield fitted with a proper shade filter (refer AS 60974-1, AS/NZS 1337.1 and AS/NZS 1338.1 Safety Standards) to protect your face and eyes when welding or watching. (See Filter Table later in this section)
2. Wear approved safety glasses. Side shields are recommended.
3. Use protective screens or barriers to protect others from flash and glare; warn others not to watch the arc.
4. Wear protective clothing made from durable, flame-resistant material (wool and leather) and foot safety protection.
5. Never wear contact lenses while welding.

## Noise Can Damage Hearing



### CAUTION

Noise from some processes can damage hearing. Use AS/NZS compliant ear plugs or ear muffs if the noise level is high.

## Work Environment Safety



### CAUTION

Used with the safety alert symbol, indicates a hazardous situation which, if not avoided, could result in minor or moderate injury.

1. When possible, move the work to a location well away from combustible materials. If relocation is not possible, protect the combustibles with a cover made of fire resistant material.
2. Remove or make safe all combustible materials for a radius of 10 metres around the work area. Use a fire resistant material to cover or block all doorways, windows, cracks, and other openings.
3. Enclose the work area with portable fire resistant screens. Protect combustible walls, ceilings, floors, etc., from sparks and heat with fire resistant covers.
4. If working on a metal wall, ceiling, etc., prevent ignition of combustibles on the other side by moving the combustibles to a safe location. If relocation of combustibles is not possible, designate someone to serve as a fire watch, equipped with a fire extinguisher, during the welding process and well after the welding is completed.
5. Do not weld or cut on materials having a combustible coating or combustible internal structure, as in walls or ceilings, without an approved method for eliminating the hazard.
6. After welding, make a thorough examination for evidence of fire. Be aware that visible smoke or flame may not be present for some time after the fire has started. Do not weld or cut in atmospheres containing dangerously reactive or flammable gases, vapours, liquids, and dust. Provide adequate ventilation in work areas to prevent accumulation of flammable gases, vapours, and dust.
7. Do not apply heat to a container that has held an unknown substance or a combustible material whose contents, when heated, can produce flammable or explosive vapours. Clean and purge containers before applying heat. Vent closed containers, including castings, before preheating, welding, or cutting.

## Electricity Can Kill



### DANGER!

Touching live electrical parts can cause fatal shocks or severe burns. The electrode and work circuit is electrically live whenever the output is on.

The input power circuit and machine internal circuits are also live when power is on. In semi-automatic or automatic wire welding, the wire, wire reel, drive roll housing, and all metal parts touching the welding wire are electrically live. Incorrectly installed or improperly grounded equipment is a hazard.

1. Do not touch live electrical parts.
2. Wear dry, hole-free insulating gloves and body protection.
3. Insulate yourself from the work and the ground using dry insulating mats or covers.
4. Disconnect input power before installing or servicing this equipment. Lock input power, disconnect switch open, or remove line fuses so power cannot be turned on accidentally.
5. Properly install and ground this equipment according to national, state, and local codes.
6. Turn off all equipment when not in use. Disconnect power to equipment if it will be left unattended or out of service.
7. Use fully insulated electrode holders. Never dip the holder in water to cool it or lay it down on the ground or the work surface. Do not touch holders connected to two welding machines at the same time or touch other people with the holder or electrode.
8. Do not use worn, damaged, undersized, or poorly spliced cables.
9. Do not wrap cables around your body.
10. Connect work piece to a good electrical ground.
11. Do not touch the electrode while in contact with the work (ground) circuit.
12. Use only well-maintained equipment. Repair or replace damaged parts as soon as practical.
13. In confined spaces or damp locations, do not use a plasma cutter with AC output unless equipped with a voltage reducer.

Arc rays from the welding process produce intense heat and strong ultraviolet rays that can burn eyes and skin. Use the following table to select the appropriate shade number for a Welding Helmet or Welding Face Shield.

Recommended Protective Filters for Electric Welding		
Description of Process	Approximate Range of Welding Current in Amps	Minimum Shade Number of Filter(s)
Manual Metal Arc Welding - Covered Electrodes (MMA)	Less than or equal to 100	8
	100 to 200	10
	200 to 300	11
	300 to 400	12
	Greater than 400	13
Gas Metal Arc Welding (GMAW) (MIG) other than Aluminium And Stainless Steel	Less than or equal to 150	10
	150 to 250	11
	250 to 300	12
	300 to 400	13
	Greater than 400	14
Gas Metal Arc Welding(GMAW) (MIG) Aluminium and Stainless Steel	Less than or equal to 250	12
	250 to 350	13
Gas Tungsten Arc Welding (GTAW) (TIG)	Less than or equal to 100	10
	100 to 200	11
	200 to 250	12
	250 to 350	13
	Greater than 350	14
Flux-Cored Arc Welding (FCAW) - with or without Shielding Gas	Less than or equal to 300	11
	300 to 400	12
	400 to 500	13
	Greater than 500	14
Air - Arc Gouging	Less than or equal to 400	12
Plasma - Arc Cutting	50 to 100	10
	100 to 400	12
	400 to 800	14
Plasma - Arc Spraying	—	15
Plasma - Arc Welding	Less than or equal to 20	8
	20 to 100	10
	100 to 400	12
	400 to 800	14
Submerged - Arc Welding	—	2 (5)
Resistance Welding	—	Safety Spectacles or Eye Shield

Refer to standard AS/NZS 1338.1 for comprehensive information regarding the above table.

## Fumes And Gases



### WARNING!

Welding produces fumes and gases. Breathing these fumes and gases can be hazardous to your health.

- Keep your head out of the fumes. Do not breathe the fumes.
- If inside, ventilate the area and/or use an exhaust at the arc to remove welding fumes and gases.
- If ventilation is poor, use an approved air-supplied respirator.
- Read the Safety Data Sheets (SDS) and the manufacturer's instruction for the metals, consumables, coatings, and cleaners.
- Work in a confined space only if it is well ventilated, or while wearing an air-supplied respirator. Shielding gases used for welding can displace air causing injury or death. Be sure the breathing air is safe.
- Do not weld in locations near degreasing, cleaning, or spraying operations. The heat and rays of the arc can react with vapours to form highly toxic and irritating gases.
- Do not weld on coated metals, such as galvanized, lead, or cadmium plated steel, unless the coating is removed from the weld area, the area is well ventilated, and if necessary, while wearing an air-supplied respirator. The coatings and any metals containing these elements can give off toxic fumes if welded.



## Fire & Explosive Risks



### WARNING!

Sparks and spatter fly off from the welding arc. The flying sparks and hot metal, weld spatter, work piece, and hot equipment can cause fires and burns.

Accidental contact of electrode or welding wire to metal objects can cause sparks, overheating, or fire.

1. Protect yourself and others from flying sparks and hot metal.
2. Do not weld where flying sparks can strike flammable material.
3. Remove all flammables within 10m of the welding site.
4. Be alert that welding sparks and hot materials from welding can easily go through small cracks and openings to adjacent areas.
5. Watch for fire, and keep a fire extinguisher nearby.
6. Be aware that welding on a ceiling, floor, bulkhead, or partition can cause fire on the hidden side.
7. Do not weld on closed containers such as tanks or drums.
8. Connect the work lead/clamp to the job as close to the welding area as practical to prevent welding current from travelling long, possibly unknown paths and causing electric shock and fire hazards.
9. Do not use a plasma cutter to thaw frozen pipes.
10. Remove the stick electrode from the holder or cut off the welding wire at the contact tip when not in use.

## Sparks & Hot Metal



### WARNING!

Chipping and grinding causes flying metal, and as welds cool they can throw off slag.

1. Wear an AS/NZS approved face shield or safety goggles. Side shields are recommended.
2. Wear appropriate safety equipment to protect the skin and body.

## WARRANTY

### Duralloy Welding Equipment / Plasma Cutting Range

#### 3 year Warranty\*

Duralloy Industrial Supply warrants the original retail purchaser that the Duralloy Welding and Cutting machines purchased will be free from defects in materials and workmanship for a period of 3 years\* from the date of purchase by the customer. If a defect in material or workmanship becomes evident during this period, Duralloy Industrial Supply will at its option;

- Repair the product (or pay for the repair of the product)
- Replace the product

In case of warranty claim the product should be returned to the original place of purchase, with proof of purchase.

Any handling and transport costs (or other expenses) incurred in claiming warranty are not covered by this warranty. The warranty schedule is:

- Duralloy Power source only\* 3 years
- Duralloy Regulator 3 months
- MIG Torches 3 months
- TIG Torches 3 months
- Plasma Torches 3 months
- Ancillary Equipment 3 months

The Obligation of Duralloy Industrial Supply under this warranty is limited to the circumstance set out above and is subject to:

- The customer being able to provide proof of purchase of the relevant equipment.
- A defect in either material or workmanship.
- The customer returning the product to Duralloy Industrial supply or an authorized repair agent.
- The product not having been altered or tampered with.
- The product not having been used outside the normal operating parameters of this equipment.
- The product to be in good condition and not damaged which may cause a fault

All goods come with a guarantee that cannot be excluded under the Australian Consumer laws. You as a consumer are entitled to a replacement or a refund for a major failure. You are also entitled to have the goods repaired or replaced if the products fail to be of acceptable quality.

This Warranty Provided by:

**Duralloy Industrial Supply** ABN 81 831 839 268  
2 Hollylea Road Leumeah NSW 2560  
1300 369 456





**DURALLOY®**

[www.duralloy.net.au](http://www.duralloy.net.au) | 1300 369 456