

DURALLOY®

MULTIMIG 200 PFC MV

OWNER'S MANUAL



Congratulations on your new DURALLOY® product!

The DURALLOY range uses latest technology design and engineering to produce welding products that combine market leading value and features with durability. Designed for discerning operators who seek professional results and product quality without the price tag of a full professional setup. Design emphasis is placed on simple, functional design and operation. DURALLOY product is subject to stringent quality control and designed and manufactured to EN60974-1.2012 standards.

Common use of DURALLOY products include:

- Light Engineering
- Automotive
- Home / Hobby Engineering
- Farming
- Industrial Maintenance & Repairs

For industrial welding solutions, check out the DURALLOY at www.duralloy.net.au

DURALLOY is a market leading provider of innovative power equipment solutions to a wide range of industries across Australia. Key product categories are; welding equipment, engineering supplies and abrasives.

CONTENTS

Know Your Machine	5
Quick Start Guide	7
Wiring Diagram	9
Care & Maintenance	10
Welding Settings	10
Basic MIG Welding Guide	11
Effects of MMA Welding Various Metals	15
Basic MMA Welding Guide	16
MMA Welding Techniques	17
MMA Troubleshooting	21
Safety	22
Warranty	27

DURALLOY®

MULTIMIG 200 PFC MV

240V Multiprocess Inverter
Welding Machine

PART NO: **DA200MMIG**



EN60974-1:2012



PFC TECHNOLOGY

Most DURALLOY® Welding Machines feature PFC Technology for maximum electrical efficiency and consistent weld output.

MULTIPURPOSE

MIG, TIG and MMA modes.

ARC STABILITY

Waveform control for added stability of the arc, even at low current.

DIGITAL DISPLAY

Variable amperage control with digital meters for a simultaneous welding current and voltage display.

PROTECTION

Equipped with temperature, voltage and current sensors for greater protection.

FEATURES

- Generator friendly (8.5Kva)
- Spool gun function (optional)
- Suits 1kg & 5kg Spools
- Voltage Reduction Device (VRD)
- 2 roll wire feeder
- Industrial cable connectors (35-50)
- Industrial Binzel style MIG torch MB24
- Switched 4 M TIG torch (optional)
- Wide input voltage - 90VAC - 275VAC
- Gas/Gasless MIG Operation
- Wire Inch Switch
- Gas Purge switch
- Quick connect gas fittings
- Protective front fascia cover
- IP23 rating
- Extension lead friendly up to 100m

SPECIFICATIONS

Power Supply	90VAC - 275VAC					
Supply Plug	15 Amp					
Frequency	50/60Hz					
	1-110/120/130V ± 10%			1-220/230/240V ± 10%		
	MIG	MMA	TIG	MIG	MMA	TIG
Input Power	4kW	3.5kW	3.2kW	6.2kW	6.2kW	4.2kW
Input Current	37.8A	32A	29A	29A	30A	20A
Duty Cycle 40°C 10min	140A 35% 110A 60% 85A 100%	110A 30% 80A 60% 65A 100%	150A 40% 125A 60% 95A 100%	200A 30% 145A 60% 110A 100%	200A 25% 130A 60% 100A 100%	200A 35% 155A 60% 120A 100%
No Load Voltage	65V					
Welding Current	40A - 200A					
Welding Voltage	14V - 24V					
Efficiency	80%					
Power Factor	0.99					
Wire Diameter	Fe: 0.6 - 0.9 Ss: 0.8/0.9 Flux-Cored: 0.8 - 1.2 AL: 0.9/1.0					
Net Weight	15kg					
Dimensions	511mm x 213mm x 400mm					
Insulation Class	H					
Protection Class	IP23					
Cooling	Auto Fan					

APPLICATIONS

- Maintenance
- General Fabrication
- Rural Applications
- On-site Fabrication

MATERIALS

- Mild Steel
- Aluminium
- Stainless Steel

PACKAGE INCLUDES

- Power Source
- 3M MB 24 Style MIG Torch
- 3M Earth Lead
- 3M MMA Arc Lead
- 1.5M Gas Hose
- Argon Regulator
- Owner's Manual

KNOW YOUR MACHINE

More detailed explanations of function on following pages.

1. MIG Wire Feed Speed/ MMA/TIG Current Control*
2. MIG Voltage/MMA Arc Force/Downslope Adjustment Knob*
3. MIG Mode Indicator
4. MMA Mode Indicator
5. TIG Mode Indicator
6. Wire Feed Speed/ Current Display Meter*
7. Display Value Indicator- Wire Feeding Speed
8. Display Value Indicator- Current
9. Voltage/ Arc Force / TIG Display Meter*
10. Display Value Indicator- Voltage (when in MIG mode)
11. Display Value Indicator- Arc Force (when in MMA mode)
12. Display Value Downslope when in TIG Mode
13. Power Indicator. Lights when input power connected and machine switched On (When in TIG Mode).
14. Error/ Overload Indicator*
15. Mig Wave Control/ Inductance Knob*
16. Trigger Switch Selector 2T/4T
17. Negative (-) Welding Power Output Connection Socket
18. Gas hose connector for optional TIG torch
19. Aero Socket For Optional TIG Torch connection
20. MIG Torch Euro Connect Socket
21. Positive(+) Output Welding Connection

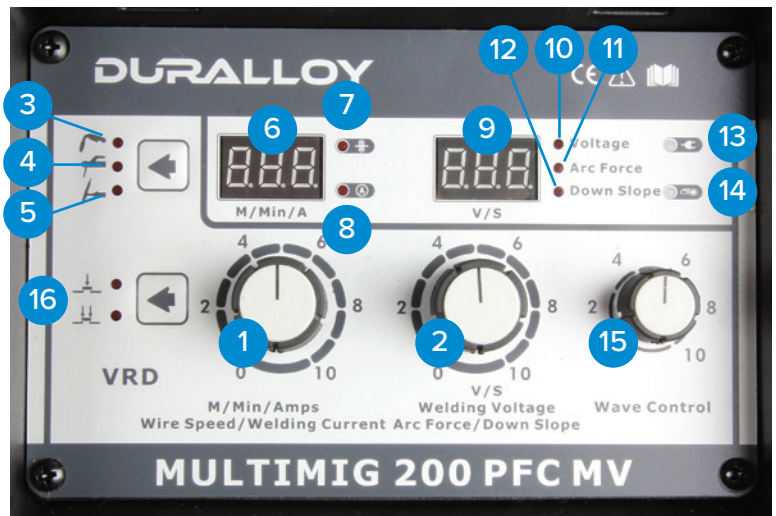

FURTHER CONTROLS EXPLAINED

MIG Wire Feed Speed/MMA/TIG Current Control Knob

In MIG mode this knob sets the wire feeding speed in MMA/TIG mode, sets MMA/TIG welding current

MIG Voltage/ MMA Arc Force Adjustment Knob

In MIG mode this knob sets the welding voltage. In MMA mode, sets arc force. In TIG mode, sets downslope time.

Wire Feed Speed/ Current Display Meter

In MIG mode, displays wire feeding speed in m/minute prior to welding, during welding displays welding current output. In MMA/TIG mode, displays welding current. The display meter mode is shown by the indicator (6/7) that is lit.

Voltage/ Arc Force Display Meter

In MIG mode, displays welding voltage. In MMA mode, displays arc force adjustment. In TIG mode, displays downslope time. The display meter mode is shown by the indicator (9/10/12) that is lit.

Overload/ Error Indicator

Lights when over voltage, over current or electrical overheating (due to exceeding duty cycle) is detected and protection is activated. When protection is activated, welding output will be disabled until the safety system senses the overload has reduced sufficiently and indicator lamp goes out. May also trigger if machine experiences an internal power circuit failure.

When protection is activated, welding output will be disabled until the safety system senses the overload has reduced sufficiently and indicator lamp goes out. May also trigger if machine experiences an internal power circuit failure.

TIPS & TRICKS

Duty Cycle Rating

welding arc that sets the heat. The wire speed feed simply controls the rate at which the welding wire is fed into the weld pool. For any voltage position setting, there will be a specific corresponding 'sweet spot' in the wire feeding speed that will give the smoothest and most stable welding arc. The correct wire feeding speed for a given voltage setting is affected by welding wire type and size, shielding gas, welding material and joint type. It is recommended to set the welding voltage as desired and then slowly adjust the wire speed until the arc is smooth and stable. When reaching this point, if the penetration/ heat input is too much/ not enough, adjust the voltage setting and repeat the process. If the operator is not able to achieve a smooth and stable arc with the desired heat input for the weld, it is likely that a change in wire size and/or shielding gas type is required (assuming all other factors are correct).

Wave Control

This setting changes the MIG waveform to simulate changing the inductance of the welding circuit. Inductance controls the rate of the current rise and fall as the welding wire contacts the workpiece (known as a short circuit). More inductance increases the short circuit time and decreases the short circuit frequency rate. This causes a wider and more penetrating arc, useful for thicker weld joints. Less inductance will create a narrow more focused arc. This effect can also be used to fine tune the arc to produce less splatter. Wire speed, wire size and type, shielding gas will all change the effect that the inductance setting has on the welding arc. Inductance change will have no practical effect on MIG spray transfer process (as opposed to short circuit process), MMA or TIG welding process.

Arc Force Control

An MMA welding power source is designed to produce constant output current (CC). This means with different types of electrode and arc length; the welding voltage varies to keep the current constant. This can cause instability in some welding conditions as MMA welding electrodes will have a minimum voltage they can operate with and still have a stable arc. Arc Force control boosts the welding power if it senses the welding voltage is getting too low. The higher the arc force adjustment, the higher the minimum voltage that the power source will allow. This effect will also cause the welding current to increase. 0 is Arc Force off, 10 is maximum Arc Force. This is practically useful for electrode types that have a higher operating voltage requirement or joint types that require a short arc length such as out of position welds.

QUICK START GUIDE - WELDER INSTALLATION

Electrical Connection

The DURALLOY MULTIMIG 200 PFC MV is designed to operate on a 15A 240V AC power supply. If an extension cord must be used, it should be a heavy duty version with a minimum cable core size of 2.5mm².

Operating Environment

Adequate ventilation is required to provide proper cooling. Ensure that the machine is placed on a stable level surface where clean cool air can easily flow through the unit. The DURALLOY MULTIMIG 200 PFC MV has electrical components and control circuit boards which may be damaged by excessive dust and dirt, so a clean operating environment is important for reliable product life.

BASIC OPERATION

1. Fitting Wire Spool & Loading Wire Feeder

- 1.1 Open the wire compartment cover. Unthread the wire spool retainer. Fit the wire spool to spool holder shaft, ensuring that the wire exits the spool towards the bottom the spool.
- 1.2 Set the spool brake tension by adjusting the spool tension adjustment screw before replacing the wire spool retainer. The spool brake tension should be set so that the spool can rotate freely, but does not continue to rotate once the wire feed stops. This may need to be adjusted as the wire is used up and the spool weight decreases.



WARNING! Excessive spool brake tension will cause wire feeding issues and affect welding performance as well as premature failure/ wear of wire feed components.

- 1.3 Feed the wire from the spool through the wire drive inlet guide into the wire feeder.
- 1.4 Release the wire feed tension arms by pivoting the wire feed tension adjustment lever from the vertical to the horizontal position.
- 1.5 Check the wire drive roller grooves match the selected MIG wire type and size. The drive roller will have two different sized grooves; the size of the groove in use is stamped on the side of the drive roller. For flux cored 'soft' wire, such as that used in gasless MIG welding, the drive roller groove has a serrated profile (known as knurled). For solid core 'hard' MIG wire, the drive roller groove used has a 'V' shaped profile. For Aluminium solid core 'soft' MIG wire, the drive roller required has a 'u' shaped groove. If necessary, remove and change the drive roller by unthreading the drive roller retainer.

- 1.6 Once the correct drive rollers are selected and fitted, manually feed the wire through the wire drive inlet guide through the drive roller grooves and into the brass outlet wire guide tube. Ensuring that the wire is correctly seated in the drive roller grooves, replace the wire feed tension arms and lock them into place by rotating the wire feed tension adjustment lever back to the vertical position.

Adjusting wire feed tension: this is accomplished by winding the knob on the tension adjustment lever. Clockwise will increase tension, anti-clockwise will decrease drive tension. Ideal tension is as little as possible, while maintaining a consistent wire feed with no drive roller slippage.

Check all other causes of excess wire feeding friction causing slippage first, such as; incorrect/ worn drive roller, worn/ damaged torch consumables, blocked/damaged torch wire guide liner, before increasing wire feed tension. There is a number scale on the tension adjustment lever to indicate the adjustment position. The higher the number indicated, the higher the tension that is set.



WARNING! Before changing the feed roller or wire spool, ensure that the mains power is switched off.



WARNING! The use of excessive feed tension will cause rapid and premature wear of the drive roller, the support bearing and the drive motor/ gearbox.

- 1.7 Connect the MIG Torch Euro Connector to the MIG torch Euro connection socket (20) on the front of the machine. Secure by firmly hand tightening the threaded collar on the MIG Torch connector clockwise.
- 1.8 Check that the correct matching MIG wire, drive rollers and MIG torch tip are fitted.
- 1.9 Connect the machine to suitable mains power using the mains input power lead. Switch the mains power switch to 'on' to power up the machine. Select the welding mode button so MIG mode indicator (3) is lit. Adjust the wire feed speed control (1) to maximum.
- 1.10 You are now ready to feed the wire through the torch. With the wire feeder cover open, pull the trigger of the MIG torch to check that the wire is feeding smoothly through the feeder and into the torch. This can also be performed by using the wire feed toggle switch situated above wire feed assembly.
- 1.11 With the tip removed from the torch and the torch laid out as straight as possible, activate the torch trigger until the wire feeds out through the end of the MIG torch. Replace the tip on the MIG torch and trim off any excess wire. This can also be performed by using the wire feed toggle switch located above wire feed assembly.

2. Gasless Welding Operation

- 2.1 Connect the earth cable quick connector to the positive welding power output socket (21). Connect the earth clamp to the work piece. Contact with the work piece must be firm contact with clean, bare metal, with no corrosion, paint or scale at the contact point.
- 2.2 Change Polarity link which is situated above Wire feed system to the Horizontal plane.
- 2.3 Set the welding voltage adjustment knob (2), wire speed control knob (1) and wave control knob (15) to the desired positions. You are now ready to weld!

3. Gas Shielded Welding Operation

- 3.1 Connect the earth cable quick connector to the negative welding power output socket (17) Connect the earth clamp to the work piece. Contact with the work piece must be firm contact with clean, bare metal, with no corrosion, paint or scale at the contact point.
- 3.2 Change polarity Link which is situated above the wire feed system to the Vertical plane.
- 3.3 Assemble the female gas quick connector to the gas line and to the regulator outlet fitting. Connect the gas regulator to a gas cylinder (not included with machine) and connect the female quick connector to the male gas inlet on the rear of the machine. Ensure all connections are tight. Open gas cylinder valve and adjust regulator, flow should be between 10-25 l/min depending on application. This can be done by using gas purge toggle switch situated above wire feed assembly.
- 3.4 Set the welding voltage adjustment knob (2), wire speed control knob (1) and wave control knob (15) to the desired positions. You are now ready to weld!

Note: MIG welding with aluminium provides a unique challenge, due to the low column strength of the wire. This causes the wire to deform more as it is pushed through the feed mechanism and the torch wire delivery liner, greatly increasing friction. Because good MIG welding results are dependent on a smooth wire feed, certain changes must be made to the wire feed system to minimise friction caused issues.

For a standard 'push' fed torch, a length of no longer than 3m cable may be used, as well as the torch feed liner must be changed to a special Teflon/ PVC liner, rather than the conventional steel liner. Also the correct style drive roller must be used and specific Aluminium rated torch contact tip (or a standard tip in one size oversize, e.g. 0.8mm aluminium wire, use standard 1.0mm contact tip). For this reason, it is quite common for operators to have an extra MIG torch specifically set up for aluminium use, if the machine is used for welding steel as well.

Another option to overcome the friction issues is using a spool gun, which will give better results than a 3m push torch when welding aluminium.

4. ARC/ MMA Welding Operation

- 4.1 Connect the earth cable quick connector to the negative welding power output socket (17) Connect the earth clamp to the work piece. Contact with the work piece must be firm contact with clean, bare metal, with no corrosion, paint or scale at the contact point.
- 4.2 Insert an electrode into the electrode holder and connect the electrode holder and work lead to the positive welding power output socket (21).

Note: This polarity connection configuration is valid for most GP (General Purpose) MMA electrodes. There are variances to this. If in doubt, check the electrode specifications or consult the electrode manufacturer.

- 4.3 Connect the machine to suitable mains power using the mains input power lead. Switch the mains power switch to 'on' to power up the machine. Set the welding mode to MMA (4).
- 4.4 Select the required output current (1) and arc force (2). You are now ready to weld!

5. Lift TIG Operation

Note: Lift TIG operation requires an optional DURALLOY TIG TORCH 174TTM, and argon gas cylinder.

- 2.1 Connect the earth cable quick connector to the positive welding power output socket (21). Connect the earth clamp to the work piece. Contact with the work piece must be firm contact with clean, bare metal, with no corrosion, paint or scale at the contact point.
- 2.2 Insert TIG torch power connection into the negative welding power output socket (17). Insert Aero Plug from TIG torch into (19). This plug can only fit in 1 way, please line up prior to fitting. Fit Gas Hose Connector on TIG torch into (18) quick connect fitting
- 2.3 Open gas cylinder valve and adjust regulator, flow should be between 5-10 l/min depending on application. Re-check regulator flow pressure with TIG Torch Switch as static gas flow setting may drop once gas is flowing.
- 2.4 Connect the machine to suitable mains power using the mains input power lead. Switch the mains power switch to 'on' to power up the machine. Select Lift TIG welding mode (5) using the button.
- 2.5 Select the required output current using the current control knob (1). Depress Button on TIG Torch ensuring 2T setting is selected on machine. Arc will start once tungsten IS lifted FROM THE BASE MATERIEAL.

WIRING DIAGRAM

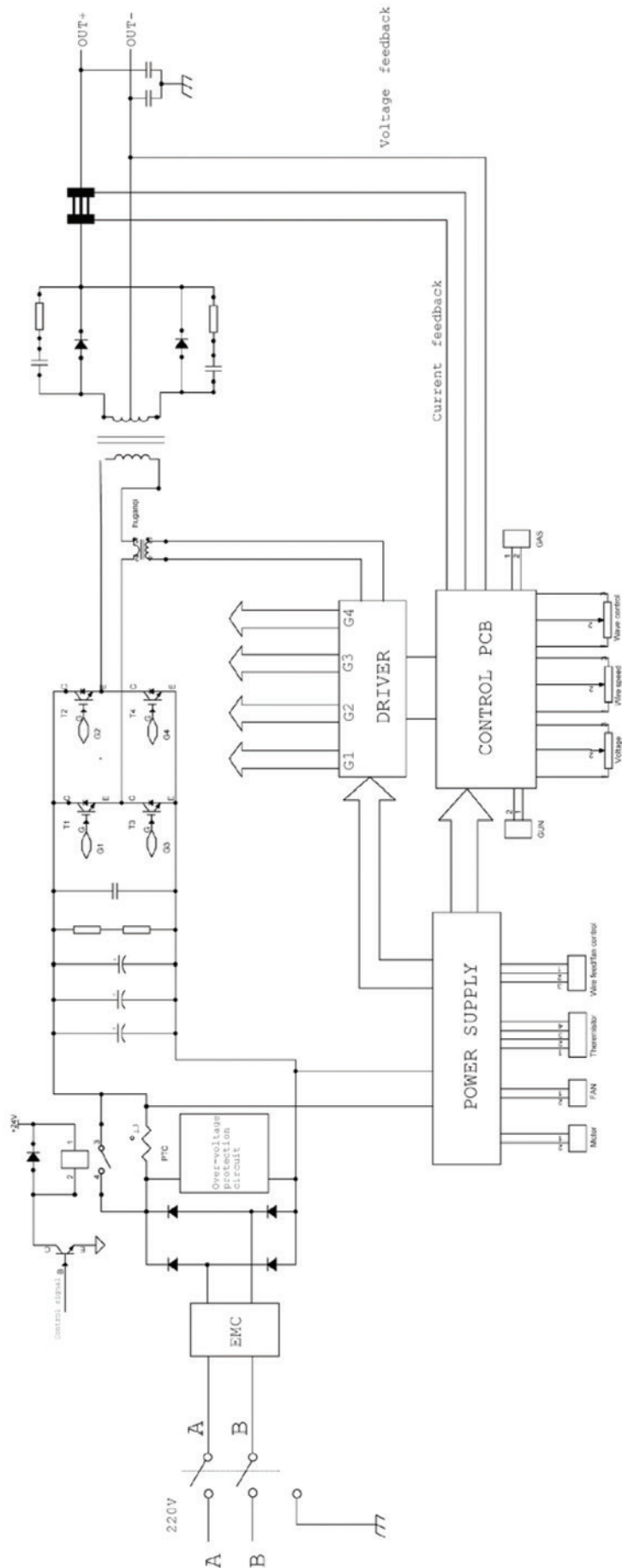

CARE & MAINTENANCE

Keep your welding machine in top condition

The DURALLOY MULTIMIG 200 PFC MV does not require any special maintenance, however the user should take care of the machine as follows:

- Regularly clean the ventilation slots.
- Keep the casing clean.
- Check all cables before use.
- Check electrode holders, work lead/clamps and welding torches before use.
- Replace worn electrode holders and earth clamps, which do not provide a good connection.
- Replace worn consumable parts in a timely manner.
- Use a soft cloth or brush to clean electrical components.
- Do not use liquid cleaning products, water or especially solvents.
- Do not use compressed air to clean electrical components as this can force dirt and dust further into components, causing electrical short circuits.

- Check for damaged parts. Do not use the welder with damaged parts.
- A damaged welder must be carefully checked by a qualified person to determine that it will operate properly. Check for breakage of parts, mountings and other conditions that may affect its operation. An authorised service centre should properly repair a damaged part. Have your welder repaired by an expert.

This appliance is manufactured in accordance with relevant safety standards. Only experts must carry out repairing of electrical appliances, otherwise considerable danger for the user may result. Use only genuine replacement parts. Do not use modified or non-genuine parts.

Storing the Welder

When not in use the welder should be stored in the dry and frost-free environment.



WARNING!

Before performing cleaning/maintenance, replacing cables / connections, make sure the welding machine is switched off and disconnected from the power supply.

WELDING SETTINGS

MIG Welding Parameter						Material Thickness				
Welding Material	Wire Type	Polarity	Wire Size	Drive Roller Type	Shielding Gas	1.0mm	3.0mm	5.0mm	8.0mm	10.0mm
						Settings Key: Voltage/ Wirespeed/ Inductance*				
Mild Steel	Self Shielded Flux Core	Torch Negative (-)	0.8mm	Knurled Groove	N/A	1/2/5	2/3/5	3/4/5	4/5/5	-
Mild Steel	Self Shielded Flux Core	Torch Negative (-)	0.9mm	Knurled Groove	N/A	-	2/2/5	3/3/5	4/4/5	-
Mild Steel	Solid Wire ER70S-6	Torch Positive (+)	0.6mm	V Groove	75% Argon + 25% CO ₂	1/4/0	3/5/0	-	-	-
Mild Steel	Solid Wire ER70S-6	Torch Positive (+)	0.8mm	V Groove	75% Argon + 25% CO ₂	-	3/3/0	4/4.5/0	5/5/0	-
Mild Steel	Solid Wire ER70S-7	Torch Positive (+)	0.9mm	V Groove	75% Argon + 25% CO ₂	-	-	3/4/0	4/5/0	5/6/0
Mild Steel	Solid Wire ER70S-6	Torch Positive (+)	0.6mm	V Groove	100% CO ₂	1.5/4/0	4/5/0	-	-	-
Mild Steel	Solid Wire ER70S-6	Torch Positive (+)	0.8mm	V Groove	100% CO ₂	-	4/4/0	5/4/0	6/5/0	-
Mild Steel	Solid Wire ER70S-7	Torch Positive (+)	0.9mm	V Groove	100% CO ₂	-	-	5/4.5/0	5/5/0	6/6/0
Aluminum for use with Spool Gun										
Aluminum	Aluminum 5356 Alloy	Torch Positive (+)	0.8mm	U Groove	100% Argon	-	2.5/2/0	3.5/2.5/0	-	-

Use a chart as guide only, as optimal settings will vary with weld joint type and operator technique. Cells left blank not recommended combination for effective welding results.

*Inductance adjustment controls the rate of the welding current rise and fall as the welding wire contacts the workpiece (known as short circuit). More inductance increases the short circuit time and decreases the short circuit frequency rate. This causes a wider and more penetrating arc, useful for thicker weld joints. Less inductance will create a narrow, more focused arc. This effect can also be used to fine tune the arc to produce less splatter. Wire speed, wire size and type, shielding gas will all change the effect that the inductance has on the welding arc. Inductance setting will have no effect on MIG spray transfer process (as opposed to short circuit process), MMA or TIG welding process.

BASIC MIG WELDING GUIDE

Two different welding processes are covered in this section (GMAW and FCAW), with the intention of providing the very basic concepts in MIG welding, where a welding gun is hand held, and the electrode (welding wire) is fed into a weld puddle, and the arc is shielded by a gas (GMAW) or flux cored wire (FCAW).

Gas Metal ARC Welding (GMAW)

This process, also known as MIG welding, CO₂ welding, Micro Wire Welding, short arc welding, dip transfer welding, wire welding etc., is an electric arc welding process which fuses together the parts to be welded by heating them with an arc between a solid continuous, consumable electrode and the work.

Shielding is obtained from an externally supplied welding grade shielding gas. The process is normally applied semi automatically; however the process may be operated automatically and can be machine operated. The process can be used to weld thin and fairly thick steels, and some non-ferrous metals in all positions.

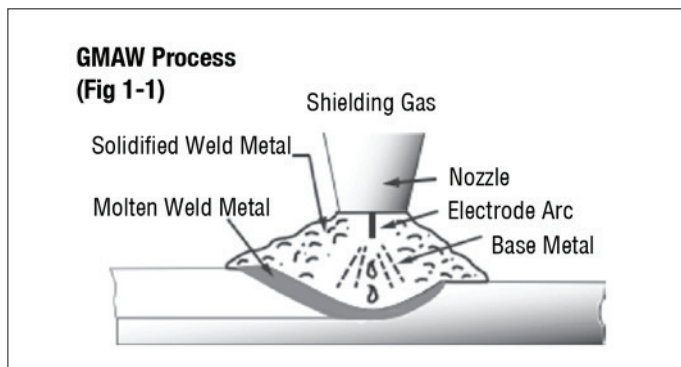

Flux Cored Arc Welding (FCAW)

This is an electric arc welding process which fuses together the parts to be welded by heating them with an arc between a continuous flux filled electrode wire and the work. Shielding is obtained through decomposition of the flux within the tubular wire. Additional shielding may or may not be obtained from an externally supplied gas or gas mixture. The process is normally applied semi automatically; however the process may be applied automatically or by machine.

It is commonly used to weld large diameter electrodes in the flat and horizontal position and small electrode diameters in all positions. The process is used to a lesser degree for welding stainless steel and for overlay work.

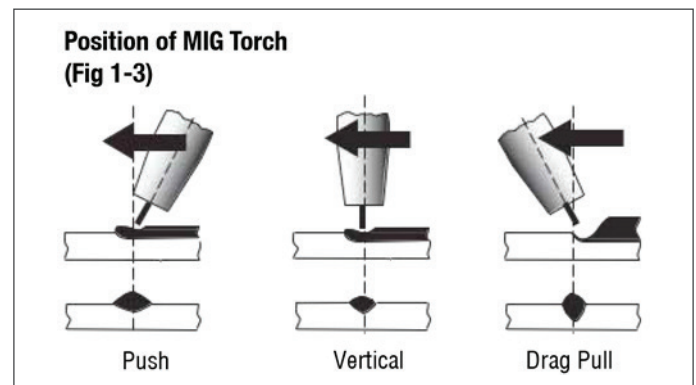
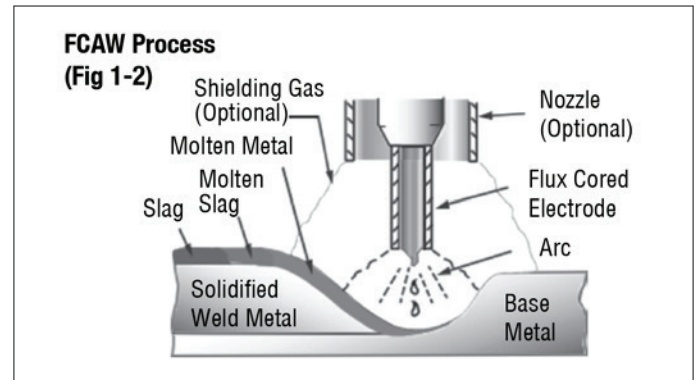

The angle of MIG torch to the weld has an effect on the width of the weld.

The welding gun should be held at an angle to the weld joint. (See Secondary Adjustment Variables below).

Hold the gun so that the welding seam is viewed at all times. Always wear the welding helmet with proper filter lenses and use the proper safety equipment.



CAUTION

Do not pull the welding gun back when the arc is established. This will create excessive wire extension (stick-out) and make a very poor weld.

The electrode wire is not energized until the gun trigger switch is depressed. The wire may therefore be placed on the seam or joint prior to lowering the helmet.

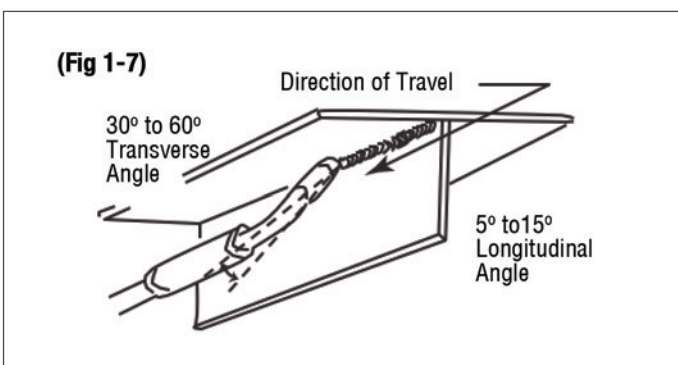
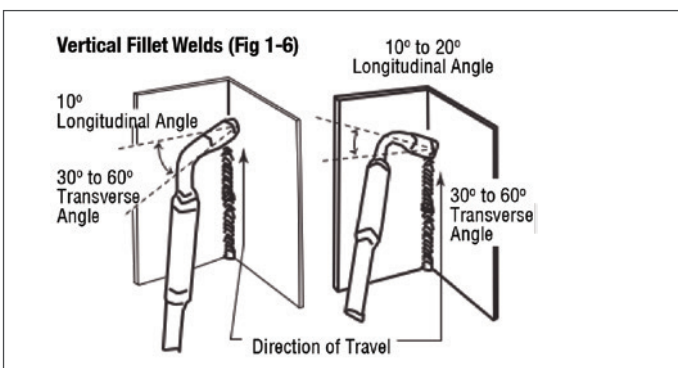
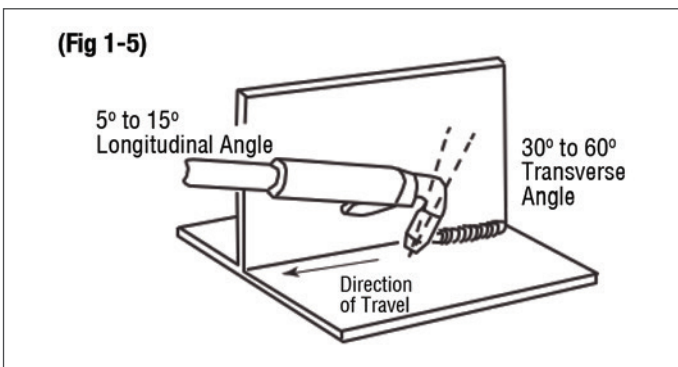
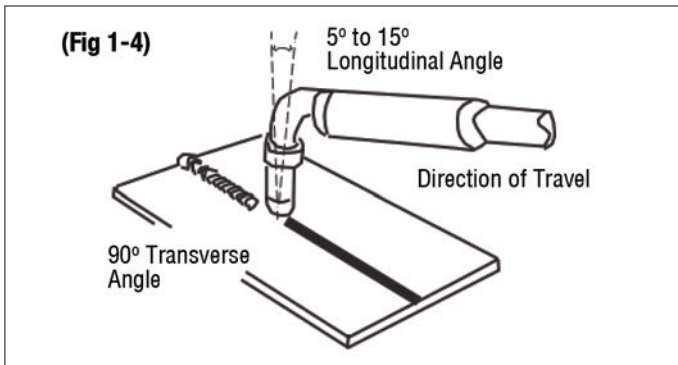

Distance from the MIG torch nozzle to the work piece

The electrode wire stick out from the MIG torch nozzle should be between 10mm to 20mm. This distance may vary depending on the type of joint that is being welded.

MIG Welding (GMAW) Variables

Most of the welding done by all processes is on carbon steel. The items below describe the welding variables in short-arc welding of 24gauge (0.024", 0.6mm) to ¼" (6.4mm) mild sheet or plate.

The applied techniques and end results in the GMAW process are controlled by these variables.

Preselected Variables

Preselected variables depend upon the type of material being welded, the thickness of the material, the welding position, the deposition rate and the mechanical properties.

These variables are:

- Type of electrode wire
- Size of electrode wire
- Type of gas
- Gas flow rate

Primary Adjustable Variables

These control the process after preselected variables have been found. They control the penetration, bead width, bead height, arc stability, deposition rate and weld soundness.

They are:

- Arc Voltage
- Welding current (wire feed speed)
- Travel speed

Secondary Adjustable Variables

These variables cause changes in primary adjustable variables which in turn cause the desired change in the bead formation.

They are:

1. **Stick-Out** - (distance between the end of the contact tube (tip) and the end of the electrode wire). Maintain at about 10mm stick-out
2. **Wire Feed Speed** - increase in wire feed speed increases weld current. Decrease in wire feed speed decreases weld current.
3. **Nozzle Angle** - This refers to the position of the welding gun in relation to the joint. The transverse angle is usually one half the included angle between plates forming the joint. The longitudinal angle is the angle between the centre line of the welding gun and a line perpendicular to the axis of the weld.

Establishing the Arc and Making Weld Beads

Before attempting to weld on a finished piece of work, it is recommended that practice welds be made on a sample metal of the same material as that of the finished piece.

The easiest welding procedure for the beginner to experiment with MIG welding is the flat position. The equipment is capable of flat, vertical and overhead positions.

For practicing MIG welding, secure some pieces of 16 or 18 gauge (1.5mm or 2.0mm) mild steel plate (150 x 150mm). Use (0.8mm) flux cored gasless wire or a solid wire with shielding gas.

Setting of the Power Source

Power source and Current (Wire Speed) setting requires some practice by the operator, as the welding plant has two control settings that have to balance. These are the Current (Wire Speed) control and the welding Voltage Control.

The welding current is determined by the Current (Wire Speed) control, the current will increase with increased Current (Wire Speed), resulting in a shorter arc. Less Current (Wire Speed) will reduce the current and lengthen the arc. Increasing the welding voltage hardly alters the current level, but lengthens the arc. By decreasing the voltage, a shorter arc is obtained with a little change in current level.

When changing to a different electrode wire diameter, different control settings are required. A thinner electrode wire needs more Current (Wire Speed) to achieve the same current level.

A satisfactory weld cannot be obtained if the Current (Wire Speed) and Voltage settings are not adjusted to suit the electrode wire diameter and the dimensions of the work piece.

If the Current (Wire Speed) is too high for the welding voltage, "sticking" will occur as the wire dips into the molten pool and does not melt.

Welding in these conditions normally produces a poor weld due to lack of fusion. If, however, the welding

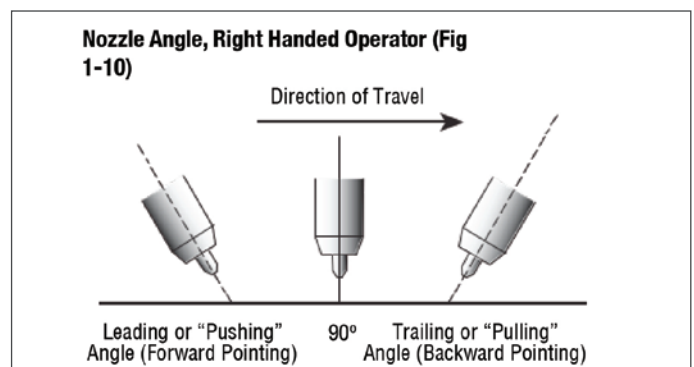
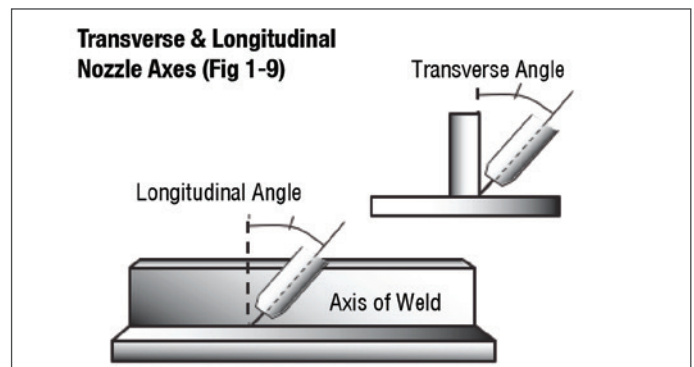
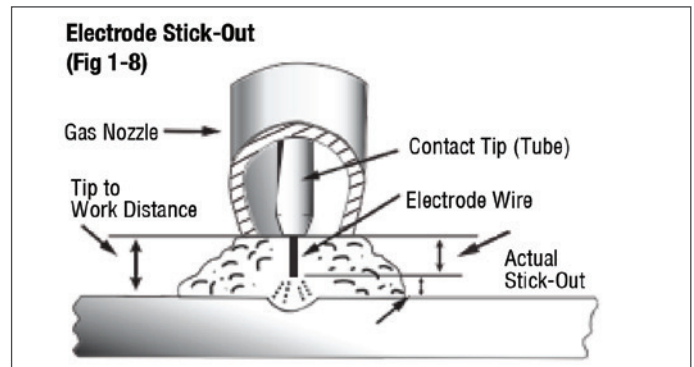

voltage is too high, large drops will form on the end of the wire, causing spatter. The correct setting of voltage and Current (Wire Speed) can be seen in the shape of the weld deposit and heard by a smooth regular arc sound.

Electrode Wire Size Selection

The choice of Electrode wire size and shielding gas used depends on the following:

- Thickness of the metal to be welded
- Type of joint
- Capacity of the wire feed unit and power source
- The amount of penetration required
- The deposition rate required
- The bead profile desired
- The position of welding
- Cost of the wire

MIG WELDING TROUBLESHOOTING

The general approach to fix Gas Metal Arc Welding (GMAW) problems is to start at the wire spool then work through to the MIG torch. There are two main areas where problems occur with GMAW, Porosity and Inconsistent wire feed.

When there is a gas problem the result is usually porosity within the weld metal. Porosity always stems from some contaminant within the molten weld pool which is in the process of escaping during solidification of the molten metal.

Contaminants range from no gas around the welding arc to dirt on the workpiece surface. Porosity can be reduced by checking the following points.

Troubleshooting - Porosity	
Fault	Cause
Shielding gas cylinder contents and flow meter.	Ensure that the shielding gas cylinder is not empty and the flow meter is correctly adjusted to 15 litres per minute.
Gas leaks.	Check for gas leaks between the regulator/cylinder connection and in the gas hose to the Power Source.
Internal gas hose in the Power Source.	Ensure the hose from the solenoid valve to the torch adaptor has not fractured and that it is connected to the torch adaptor.
Welding in a windy environment.	Shield the weld area from the wind or increase the gas flow.
Welding dirty, oily, painted, oxidised or greasy plate.	Clean contaminates off the work piece.
Distance between the MIG torch nozzle and the work piece.	Keep the distance between the MIG torch nozzle and the work piece to a minimum.
Maintain the MIG torch in good working order.	Ensure that the gas holes are not blocked and gas is exiting out of the torch nozzle.
	Do not restrict gas flow by allowing spatter to build up inside the torch nozzle.
	Check that the MIG torch O-rings are not damaged.



WARNING! Disengage the feed roll when testing for gas flow by ear.

Wire feeding problems can be reduced by checking the following points.

Troubleshooting - Wire Feed	
Fault	Cause
Feed roller driven by motor in the cabinet slipping.	Wire spool brake is too tight.
Wire spool unwound and tangled.	Wire spool brake is too loose.
Worn or incorrect feed roller size	Use a feed roller matched to the size you are welding.
	Replace feed roller if worn.
Wire rubbed against the misaligned guides affecting the wire feed.	Misalignment of inlet/outlet guides.
Liner blocked with swarf.	Increased amounts of swarf are produced by the wire passing through the feed roller when excessive pressure is applied to the pressure roller adjuster.
	Swarf can also be produced by the wire passing through an incorrect feed roller groove shape or size.
	Swarf is fed into the conduit liner where it accumulates thus reducing wire feed.
Incorrect or worn contact tip.	The contact tip transfers the weld current to the electrode wire. If the hole in the contact tip is too large then arcing may occur inside the contact tip resulting in the wire jamming in the contact tip.
	When using soft wire such as aluminium it may become jammed in the contact tip due to expansion of the wire when heated. A contact tip designed for soft wires should be used.
Poor work lead contact to work piece.	If the work lead has a poor electrical contact to the work piece then the connection point will heat up and result in a reduction of power at the arc.
Bent liner.	This will cause friction between the wire and the liner thus reducing wire feed.

Other weld problems can be reduced by checking the following points.

Troubleshooting - MIG Weld Quality		
Fault	Cause	Remedy
Undercut.	Welding arc voltage too high.	Decrease voltage or increase the wire feed speed.
	Incorrect torch angle.	Adjust angle.
	Excessive heat input.	Increase the torch travel speed and/or decrease welding current by decreasing the voltage or decreasing the wire feed speed.
Lack of penetration.	Welding current too low.	Increase welding current by increasing wire feed speed and increasing voltage.
	Joint preparation too narrow or gap too tight.	Increase joint angle or gap.
	Shielding gas incorrect.	Change to a gas which gives higher penetration.
Lack of fusion.	Voltage too low.	Increase voltage.
Excessive spatter.	Voltage too high.	Decrease voltage or increase the Current (Wire Speed) control.
	Voltage too low.	Increase the voltage or decrease Current (Wire Speed).
Irregular weld shape.	Incorrect voltage and current settings. Convex, voltage too low. Concave, voltage too high.	Adjust voltage and current by adjusting the voltage control and the Current (Wire Speed) control.
	Wire is wandering.	Replace contact tip.
	Incorrect shielding gas.	Check shielding gas.
	Insufficient or excessive heat input.	Adjust the Current (Wire Speed) control or the voltage control.
Weld cracking.	Weld bead is too small.	Decrease travel speed.
	Weld penetration narrow and deep.	Reduce current and voltage and increase MIG torch travel speed or select a lower penetration shielding gas.
	Excessive weld stresses.	Increase weld metal strength or revise design.
	Excessive voltage.	Decrease voltage.
	Cooling rate too fast.	Slow the cooling rate by preheating part to be welded or cool slowly.
Cold weld puddle.	Loose welding cable connection.	Check all welding cable connections.
	Low power supply voltage.	Contact supply authority.
Arc does not have a crisp sound that short arc exhibits when the wire feed speed and voltage are adjusted correctly.	The MIG torch has been connected to the wrong voltage polarity on the front panel.	Connect the MIG torch to the positive (+) welding terminal for solid wires and gas shielded flux cored wires. Refer to the electrode wire manufacturer for the correct polarity.

EFFECTS OF MMA WELDING VARIOUS MATERIALS

High Tensile and Alloy Steels

The two most prominent effects of welding these steels are the formation of a hardened zone in the weld area, and, if suitable precautions are not taken, the occurrence in this zone of under-bead cracks. Hardened zone and underbead cracks in the weld area may be reduced by using the correct electrodes, preheating, using higher current settings, using larger electrode sizes, short runs for larger electrode deposits or tempering in a furnace.

Manganese Steels

The effect on manganese steel of slow cooling from high temperatures causes embrittlement. For this reason it is absolutely essential to keep manganese steel cool during welding by quenching after each weld or skip welding to distribute the heat.

Cast Iron

Most types of cast iron, except white iron, are weldable. White iron, because of its extreme brittleness, generally cracks when

attempts are made to weld it. Trouble may also be experienced when welding white-heart malleable, due to the porosity caused by gas held in this type of iron.

Copper and Alloys

The most important factor is the high rate of heat conductivity of copper, making pre-heating of heavy sections necessary to give proper fusion of weld and base metal.

Types of Electrodes

ARC Welding electrodes are classified into a number of groups depending on their applications. There are a great number of electrodes used for specialised industrial purposes which are not of particular interest for everyday general work. These include some low hydrogen types for high tensile steel, cellulose types for welding large diameter pipes, etc. The range of electrodes dealt with in this publication will cover the vast majority of applications likely to be encountered; are all easy to use.

BASIC MMA WELDING GUIDE

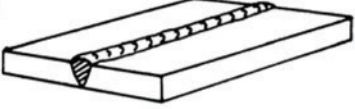
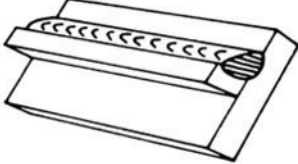
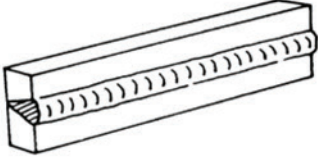
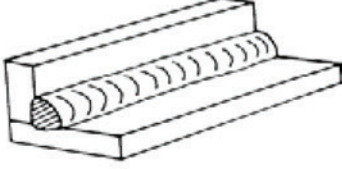
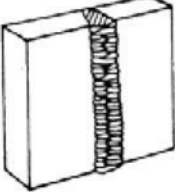
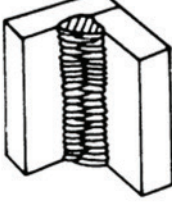
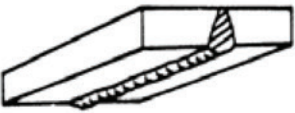
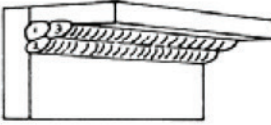
<p>Flat Position, Down Hand Butt Weld (Fig 1-11)</p>	
<p>Flat Position, Gravity Fillet Weld (Fig 1-12)</p>	
<p>Horizontal Position, Butt Weld (Fig 1-13)</p>	
<p>Horizontal-Vertical (HV) Position (Fig 1-14)</p>	
<p>Vertical Position, Butt Weld (Fig 1-15)</p>	
<p>Vertical Position, Fillet Weld (Fig 1-16)</p>	
<p>Overhead Position, Butt Weld (Fig 1-17)</p>	
<p>Overhead Position, Fillet Weld (Fig 1-18)</p>	

Joint Preparation

In many cases, it will be possible to weld steel sections without any special preparation. For heavier sections and for repair work on castings, etc., it will be necessary to cut or grind an angle between the pieces being joined to ensure proper penetration of the weld metal and to produce sound joints.

In general, surfaces being welded should be clean and free of rust, scale, dirt, grease, etc. Slag should be removed from oxy-cut surfaces. Typical joint designs are shown in Figure 1-19.

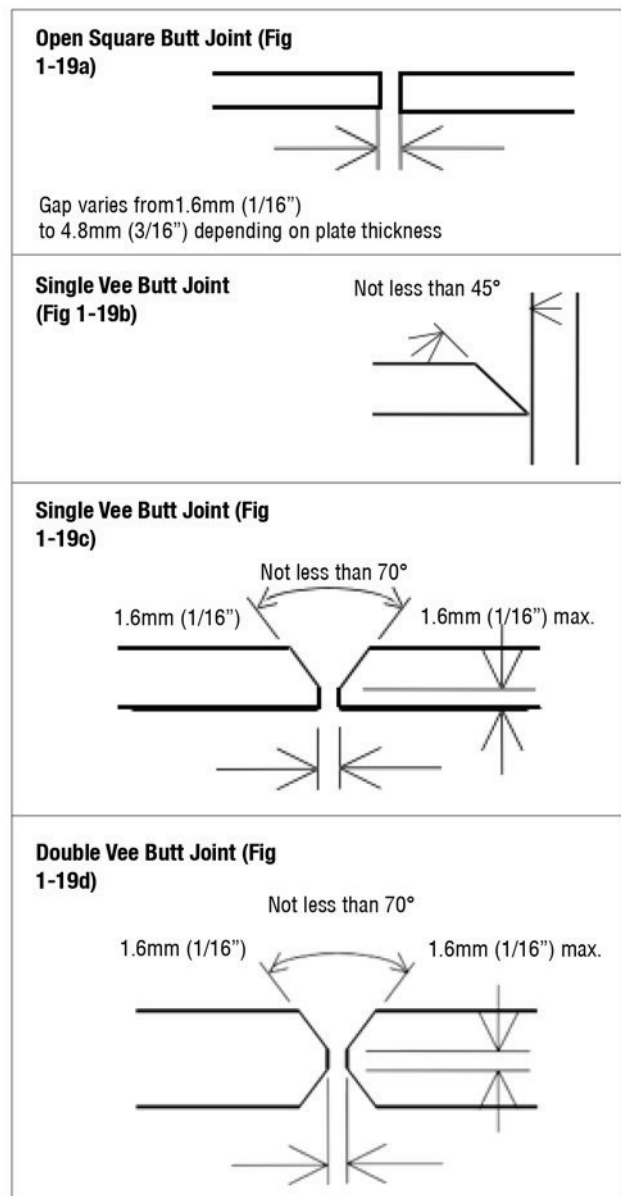

MMA WELDING TECHNIQUES

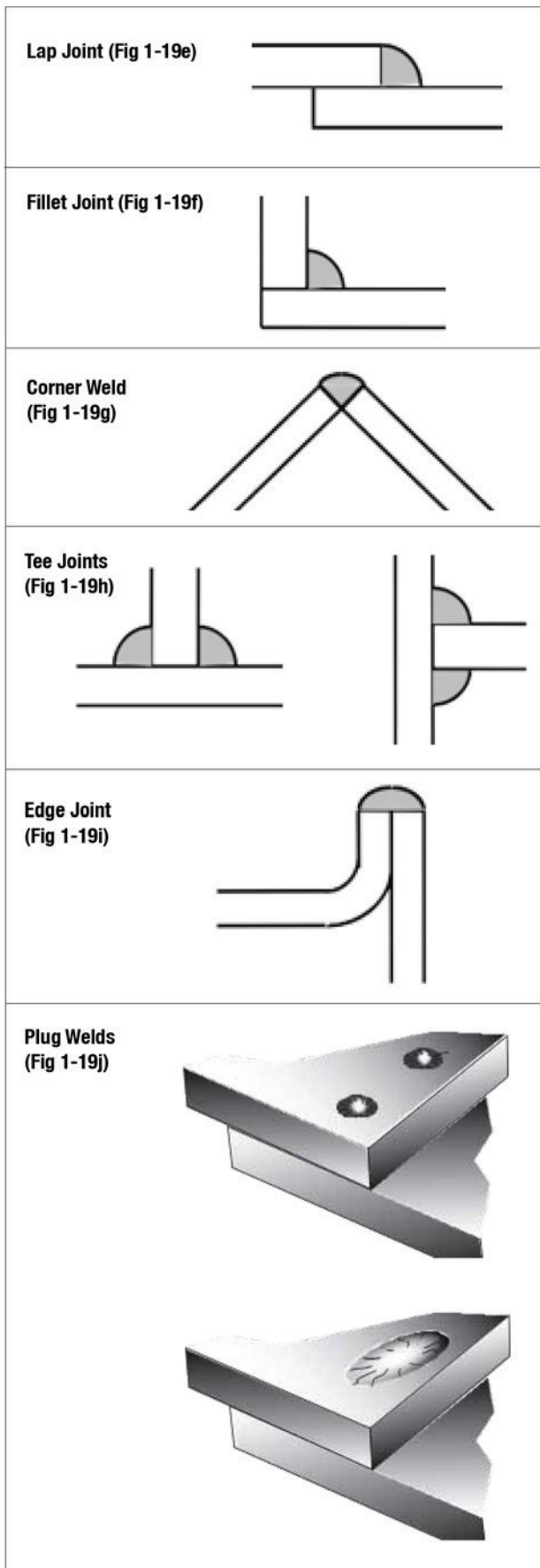

A Word for Beginners

For those who have not yet done any welding, the simplest way to commence is to run beads on a piece of scrap plate. Use mild steel plate about 6.0mm thick and a 3.2mm electrode.

Clean any paint, loose scale or grease off the plate and set it firmly on the work bench so that welding can be carried out in the down hand position. Make sure that the Work Lead/Clamp is making good electrical contact with the work, either directly or through the work table. For light gauge material, always clamp the work lead directly to the job, otherwise a poor circuit will probably result.

The Welder

Place yourself in a comfortable position before beginning to weld. Get a seat of suitable height and do as much work as possible sitting down. Don't hold your body tense. A taut attitude of mind and a tensed body will soon make you feel tired. Relax and you will find that the job becomes much easier. You can add much to your peace of mind by wearing a leather apron and gauntlets. You won't be worrying then about being burnt or sparks setting alight to your clothes.

Place the work so that the direction of welding is across, rather than to or from, your body. The electrode holder lead should be clear of any obstruction so that you can move your arm freely along as the electrode burns down. If the lead is slung over your shoulder, it allows greater freedom of movement and takes a lot of weight off your hand. Be sure the insulation on your cable and electrode holder is not faulty; otherwise you are risking an electric shock.

Striking the Arc

Practice this on a piece of scrap plate before going on to more exacting work. You may at first experience difficulty due to the tip of the electrode "sticking" to the work piece. This is caused by making too heavy a contact with the work and failing to withdraw the electrode quickly enough. A low amperage will accentuate it. This freezing-on of the tip may be overcome by scratching the electrode along the plate surface in the same way as a match is struck. As soon as the arc is established, maintain a 1.6mm to 3.2mm gap between the burning electrode end and the parent metal. Draw the electrode slowly along as it melts down.

Another difficulty you may meet is the tendency, after the arc is struck, to withdraw the electrode so far that the arc is broken again. A little practice will soon remedy both of these faults.

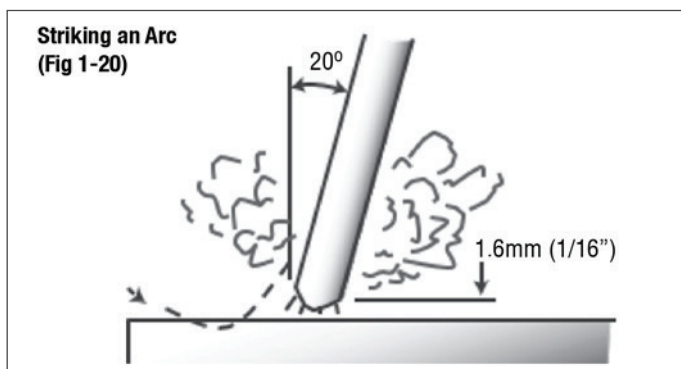

Arc Length

The securing of an arc length necessary to produce a neat weld soon becomes almost automatic. You will find that a long arc produces more heat.

A very long arc produces a crackling or spluttering noise and the weld metal comes across in large, irregular blobs. The weld bead is flattened and spatter increases. A short arc is essential if a high quality weld is to be obtained although if it is too short there is the danger of it being blanketed by slag and the electrode tip being solidified in. If this should happen, give the electrode a quick twist back over the weld to detach it. Contact or "touch-weld" electrodes such as E7014 Stick electrodes do not stick in this way, and make welding much easier.

Rate of Travel

After the arc is struck, your next concern is to maintain it, and this requires moving the electrode tip towards the molten pool at the same rate as it is melting away. At the same time, the electrode has to move along the plate to form a bead.

The electrode is directed at the weld pool at about 20° from the vertical. The rate of travel has to be adjusted so that a well-formed bead is produced.

If the travel is too fast, the bead will be narrow and strung out and may even be broken up into individual globules. If the travel is too slow, the weld metal piles up and the bead will be too large.

Rate of Travel

Having attained some skill in the handling of an electrode, you will be ready to go on to make up welded joints.

A. Butt Welds

Set up two plates with their edges parallel, as shown in Figure 1-21, allowing 1.6mm to 2.4mm gap between them and tack weld at both ends. This is to prevent contraction stresses from the cooling weld metal pulling the plates out of alignment.

Plates thicker than 6.0mm should have their mating edges bevelled to form a 70° to 90° included angle. This allows full penetration of the weld metal to the root. Using a 3.2mm E7014 Stick electrode at 100 amps, deposit a run of weld metal on the bottom of the joint.

Do not weave the electrode, but maintain a steady rate of travel along the joint sufficient to produce a well-formed bead. At first you may notice a tendency for undercut to form, but keeping the arc length short, the angle of the electrode at about 20° from vertical, and the rate of travel not too fast, will help eliminate this.

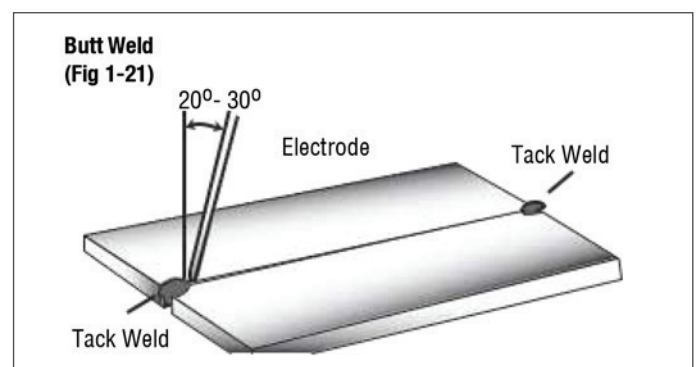

The electrode needs to be moved along fast enough to prevent the slag pool from getting ahead of the arc. To complete the joint in thin plate, turn the job over, clean the slag out of the back and deposit a similar weld.

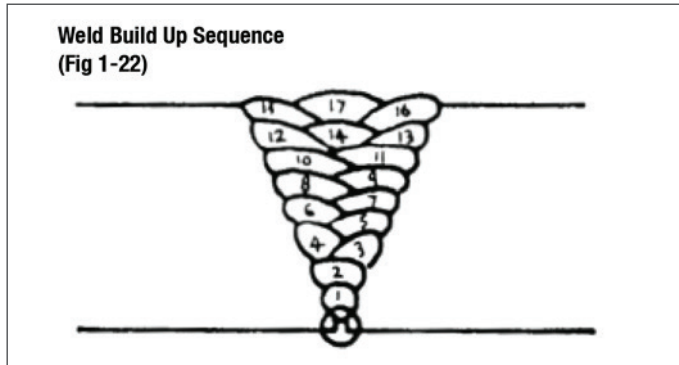

Heavy plate will require several runs to complete the joint. After completing the first run, chip the slag out and clean the weld with a wire brush. It is important to do this to prevent slag being trapped by the second run. Subsequent runs are then deposited using either a weave technique or single beads laid down in the sequence shown in Figure 1-22. The width of weave should not be more than three times the core wire diameter of the electrode.

When the joint is completely filled, the back is either machined, ground or gouged out to remove slag which may be trapped in the root, and to prepare a suitable joint for depositing the backing run. If a backing bar is used, it is not usually necessary to remove this, since it serves a similar purpose to the backing run in securing proper fusion at the root of the weld.

B. Fillet Welds

These are welds of approximately triangular crosssection made by depositing metal in the corner of two faces meeting at right angles. Refer to Figure 1-14, 1-23 and 1-24.

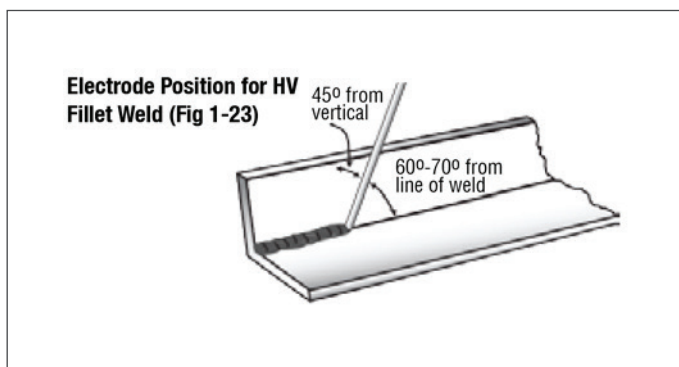

A piece of angle iron is a suitable specimen with which to begin, or two lengths of strip steel may be tacked together at right angles. Using a 3.2mm 6012 Stick electrode at 100 amps, position angle iron with one leg horizontal and the other vertical. This is known as a horizontal-vertical (HV) fillet.

Strike the arc and immediately bring the electrode to a position perpendicular to the line of the fillet and about 45° from the vertical. Some electrodes require being sloped about 20° away from the perpendicular position to prevent slag from running ahead of the weld. Refer to Figure 1-23.

Do not attempt to build up much larger than 6.4mm width with a 3.2mm electrode, otherwise the weld metal tends to sag towards the base, and undercut forms on the vertical leg. Multi-runs can be made as shown in Figure 1-24. Weaving in HV fillet welds is undesirable.

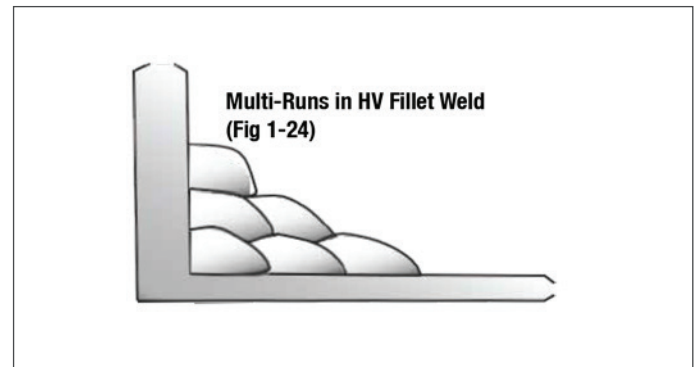

C. Vertical Welds

1. Vertical Up

Tack weld a three feet length of angle iron to your work bench in an upright position. Use a 3.2mm E7014 Stick electrode and set the current at 100 amps. Make yourself comfortable on a seat in front of the job and strike the arc in the corner of the fillet. The electrode needs to be about 10° from the horizontal to enable a good bead to be deposited. Refer Fig. 1-25.

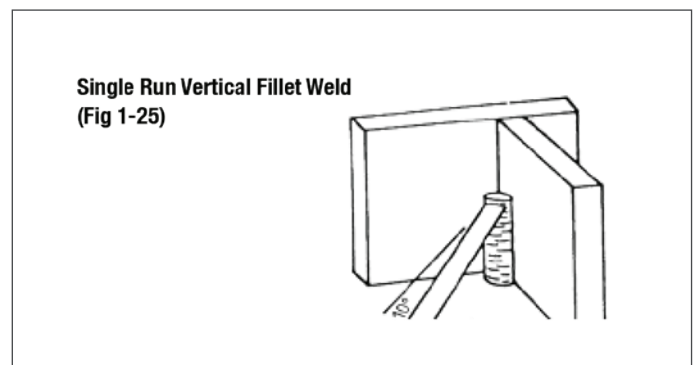

Use a short arc, and do not attempt to weave on the first run. When the first run has been completed deslag the weld deposit and begin the second run at the bottom. This time a slight weaving motion is necessary to cover the first run and obtain good fusion at the edges.

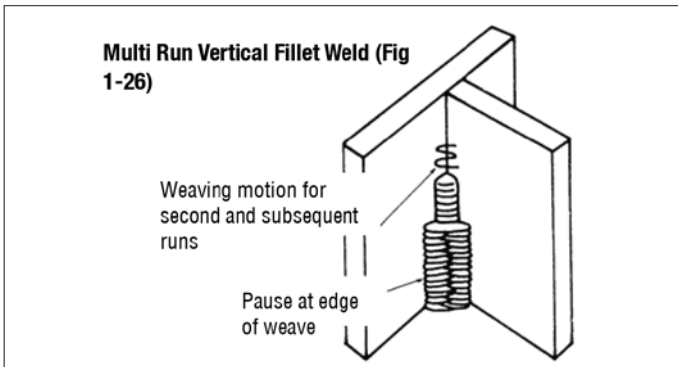

At the completion of each side motion, pause for a moment to allow weld metal to build up at the edges, otherwise undercut will form and too much metal will accumulate in the centre of the weld. Figure 1-26 illustrates multi-run technique and Figure 1-27 shows the effects of pausing at the edge of weave and of weaving too rapidly.

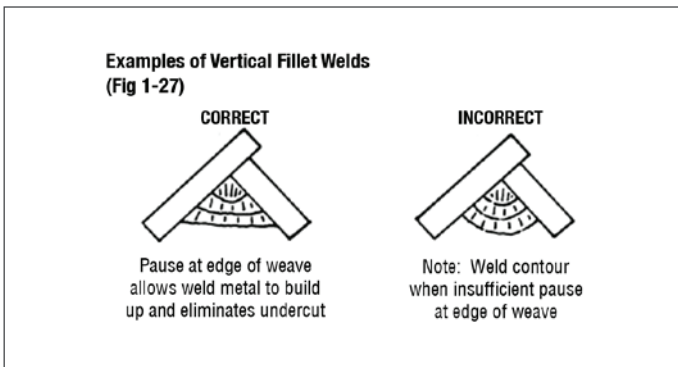

2. Vertical Down

The 6012 Stick electrode makes welding in this position particularly easy. Use a 3.2mm electrode at 100 amps. The tip of the electrode is held in light contact with the work and the speed of downward travel is regulated so that the tip of the electrode just keeps ahead of the slag. The electrode should point upwards at an angle of about 45°.

3. Overhead Welds

Apart from the rather awkward position necessary, overhead welding is not much more difficult than down hand welding.

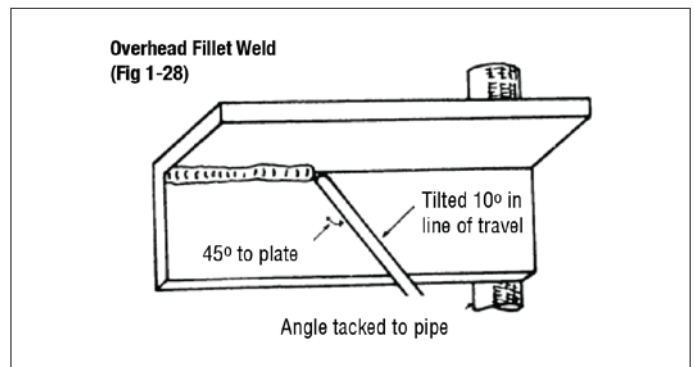

Set up a specimen for overhead welding by first tacking a length of angle iron at right angles to another piece of angle iron or a length of waste pipe. Then tack this to the work bench or hold in a vice so that the specimen is positioned in the overhead position as shown in the sketch.



The electrode is held at 45° to the horizontal and tilted 10° in the line of travel (Figure 1-28). The tip of the electrode may be touched lightly on the metal, which helps to give a steady run. A weave technique is not advisable for overhead fillet welds.

Use a 3.2mm E6013 Stick electrode at 100 amps, and deposit the first run by simply drawing the electrode along at a steady rate. You will notice that the weld deposit is rather convex, due to the effect of gravity before the metal freezes.

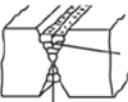
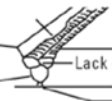
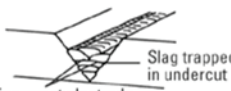
MMA TROUBLESHOOTING

Fault	Cause	Remedy
A gap is left by failure of the weld metal to fill the root of the weld.	Welding current too low.	Increase welding current.
	Electrode too large for joint.	Use smaller diameter electrode.
	Insufficient gap.	Allow wider gap.
Non-metallic particles are trapped in the weld metal.	Non-metallic particles may be trapped in undercut from previous run.	If a bad undercut is present clean slag bout and cover with a run from a smaller gauge electrode.
	Joint preparation too restricted.	Allow for adequate penetration and room for cleaning out the slag.
	Irregular deposits allow slag to be trapped.	If very bad, chip or grind out irregularities.
	Lack of penetration with slag trapped beneath weld bead.	Use smaller electrode with sufficient current to give adequate penetration. Use suitable tools to remove all slag from comers.
	Rust or mill scale is preventing full fusion.	Clean joint before welding.
	Wrong electrode for position in which welding is done.	Use electrodes designed for position in which welding is done, otherwise proper control of slag is difficult.
<p>Figure 1: Example of insufficient gap or incorrect sequence</p> <div style="display: flex; align-items: center;"> <div style="margin-right: 20px;"> <p>Incorrect Sequence</p> <p>Insufficient Gap</p> </div>  </div>		
A groove has been formed in the base metal adjacent to the toe of a weld and has not been filled by the weld metal (undercut).	Welding current is too high.	Reduce welding current.
	Welding arc is too long.	Reduce the length of the welding arc.
	Angle of the electrode is incorrect.	Electrode should not be inclined less than 45° to the vertical face.
	Joint preparation does not allow correct electrode angle.	Allow more room in joint for manipulation of the electrode.
	Electrode too large for joint.	Use smaller gauge electrode.
	Insufficient deposit time at edge of weave.	Pause for a moment at edge of weave to allow weld metal build-up.
	Power source is set for MIG (GMAW) welding.	Set power source to STICK (MMA) mode.
Portions of the weld run do not fuse to the surface of the metal or edge of the joint.	Small electrodes used on heavy cold plate.	Use larger electrodes and preheat the plate.
	Welding current is too low.	Increase welding current.
	Wrong electrode angle.	Adjust angle so the welding arc is directed more into the base metal.
	Travel speed of electrode is too high.	Reduce travel speed of electrode.
	Scale or dirt on joint surface.	Clean surface before welding.
<p>Figure 2: Example of Lack of Fusion</p> <div style="display: flex; align-items: center;"> <div style="margin-right: 20px;"> <p>Lack of fusion caused by dirt; electrode angle incorrect; rate of travel too high</p> <p>Lack of side fusion, scale dirt; small electrode; amperage too low</p> </div>  </div>		
Gas pockets or voids in weld metal (porosity)	High levels of sulphur in steel.	Use an electrode that is designed for high sulphur steels.
	Electrodes are damp.	Dry electrodes before use.
	Welding current is too high.	Reduce welding current.
	Surface impurities such as oil, grease, paint, etc.	Clean joint before welding.
	Welding in a windy environment.	Shield the weld area from the wind.
	Electrode damaged i.e. flux coating incomplete.	Discard damaged electrodes and only use electrodes with a complete flux coating.
Crack occurring in weld metal soon after solidification commences	Rigidity of joint.	Redesign to relieve weld joint of severe stresses or use crack resistance electrodes.
	Insufficient throat thickness.	Travel slightly slower to allow greater build up in throat.
	Weld current is too high.	Decrease welding current.
<p>Figure 3: Example of Slag Inclusion</p> <div style="display: flex; justify-content: space-around; align-items: center;"> <div style="text-align: center;">  <p>Slag trapped in undercut</p> <p>Not cleaned, or incorrect electrode</p> </div> <div style="text-align: center;">  <p>Slag trapped in root</p> </div> </div>		

SAFETY

Store and Retain this Manual

Retain this manual for the safety warnings and precautions, assembly, operating, inspection, maintenance and cleaning procedures. Write the product serial number at the rear of this manual and keep this manual and the receipt in a safe and dry place for future reference.

Important Safety Information

Failure to follow the warnings and instructions may result in electric shock, fire, serious injury and/or death. Save all warnings and instructions for future reference.



This is the safety alert symbol to alert you to potential personal injury hazards. Obey all safety messages that follow this symbol to avoid possible injury or death.



DANGER!

Indicates a hazardous situation which, if not avoided, will result in death or serious injury.



WARNING!

Indicates a hazardous situation which, if not avoided, could result in death or serious injury.



CAUTION

Used with the safety alert symbol, indicates a hazardous situation which, if not avoided, could result in minor or moderate injury.

NOTE: used to address practices not related to personal injury.

General Safety Warnings

1. **Maintain labels and nameplates on the welder.** These carry important information. If unreadable or missing, contact DURALLOY for a replacement.
2. **Avoid unintentional starting.** Make sure the welder is setup correctly and you are prepared to begin work before turning on the welder.
3. **Unplug before performing maintenance.** Always unplug the welder from its electrical outlet before performing any inspection, maintenance, or cleaning procedures.

4. **Never leave the welder unattended while energised.** Turn power off before leaving the welder unattended.
5. **Do not touch live electrical parts.** Wear dry, insulating gloves. Do not touch the electrode or the conductor tong with bare hands. Do not wear wet or damaged gloves.
6. **Protect yourself from electric shock.** Do not use the welder outdoors. Insulate yourself from the work piece and the ground. Use non-flammable, dry insulating material if possible, or use dry rubber mats, dry wood or plywood, or other dry insulating material large enough to cover the area of contact with the work or the ground.
7. **Avoid inhaling dust.** Some dust created by power sanding, sawing, grinding, drilling, cutting, welding and other construction activities, contain chemicals known to cause cancer, birth defects or other harm. Your risk from these exposures varies, depending on how often you do this type of work. To reduce your exposure to these chemicals, work in a well-ventilated area, and work with approved safety equipment, such as dust masks that are specially designed to filter out microscopic particles.
8. **People with pacemakers should consult their physician(s) before using this machine.**



WARNING!

Electromagnetic fields in close proximity to a heart pacemaker could cause interference, or failure of the pacemaker. The use of a Welder is NOT RECOMMENDED for pacemaker wearers. Consult your doctor.

9. **Ensure that the unit is placed on a stable location before use.**



WARNING!

If this unit falls while plugged in, severe injury, electric shock, or fire may result.

10. **Transportation Methods** Lift unit with the handles provided, or use a handcart or similar device of adequate capacity. If using a fork lift vehicle, secure the unit to a skid before transporting.



CAUTION

Disconnect input power conductors from deenergized supply line before moving the welding power source.

11. **Exercise good work practices.** The warnings, precautions, and instructions discussed in this instruction manual cannot cover all possible conditions and situations that may occur. It must be understood by the operator that common sense and caution are factors which cannot be built into this product, but must be considered by the operator.

Welding Safety Instructions & Warnings



WARNING!

Protect yourself and others from possible serious injury or death. Keep children away. Read the operating/Instruction manual before installing, operating or servicing this equipment. Have all installation, operation, maintenance, and repair work performed by qualified people.

If an operator does not strictly observe all safety rules and take precautionary actions, welding products and welding processes can cause serious injury or death, or damage to other equipment or property.

Safe practices have developed from past experience in the use of welding and cutting. These practices must be learned through study and training before using this equipment. Some of these practices apply to equipment connected to power lines; other practices apply to engine driven equipment. Anyone not having extensive training in welding and cutting practices should not attempt to weld.

Safe practices are outlined in the European Standard EN60974-1 entitled: Safety in welding and allied processes.



WARNING!

Only use safety equipment that has been approved by an appropriate standards agency. Unapproved safety equipment may not provide adequate protection. Eye and breathing protection must be AS/NZS compliant for the specific hazards in the work area.



DANGER!

Always wear AS/NZS compliant safety glasses and full face shield fitted with appropriate filter shade number. (Refer Filter Table in this safety section)



CAUTION

Heavy-duty work gloves, non-skid safety shoes and hearing protection used for appropriate conditions will reduce personal injuries.



CAUTION

Have the equipment serviced by a qualified repair person using identical replacement parts. This will ensure that the safety of the power tool is maintained.

Personal Safety



CAUTION

Keep the work area well lit. Make sure there is adequate space surrounding the work area. Always keep the work area free of obstructions, grease, oil, trash, and other debris. Do not use equipment in areas near flammable chemicals, dust, and vapours. Do not use this product in a damp or wet location.

1. Stay alert, watch what you are doing and use common sense when operating equipment. Do not use a tool while you are tired or under the influence of drugs, alcohol or medication. A moment of distraction when operating equipment may result in serious personal injury.
2. Do not overreach. Keep proper footing and balance at all times. This enables better control of the power tool in unexpected situations.

Arc Rays can Burn Eyes and Skin



DANGER!

Arc rays from the welding process produce intense heat and strong ultraviolet rays that can burn eyes and skin.

1. Use a Welding Helmet or Welding Face Shield fitted with a proper shade filter (refer AS 60974-1, AS/NZS 1337.1 and AS/NZS 1338.1 Safety Standards) to protect your face and eyes when welding or watching. (See Filter Table later in this section)
2. Wear approved safety glasses. Side shields are recommended.
3. Use protective screens or barriers to protect others from flash and glare; warn others not to watch the arc.
4. Wear protective clothing made from durable, flame-resistant material (wool and leather) and foot safety protection.
5. Never wear contact lenses while welding.

Noise Can Damage Hearing



CAUTION

Noise from some processes can damage hearing. Use AS/NZS compliant ear plugs or ear muffs if the noise level is high.

Work Environment Safety



CAUTION

Used with the safety alert symbol, indicates a hazardous situation which, if not avoided, could result in minor or moderate injury.

1. When possible, move the work to a location well away from combustible materials. If relocation is not possible, protect the combustibles with a cover made of fire resistant material.
2. Remove or make safe all combustible materials for a radius of 10 metres around the work area. Use a fire resistant material to cover or block all doorways, windows, cracks, and other openings.
3. Enclose the work area with portable fire resistant screens. Protect combustible walls, ceilings, floors, etc., from sparks and heat with fire resistant covers.
4. If working on a metal wall, ceiling, etc., prevent ignition of combustibles on the other side by moving the combustibles to a safe location. If relocation of combustibles is not possible, designate someone to serve as a fire watch, equipped with a fire extinguisher, during the welding process and well after the welding is completed.
5. Do not weld or cut on materials having a combustible coating or combustible internal structure, as in walls or ceilings, without an approved method for eliminating the hazard.
6. After welding, make a thorough examination for evidence of fire. Be aware that visible smoke or flame may not be present for some time after the fire has started. Do not weld or cut in atmospheres containing dangerously reactive or flammable gases, vapours, liquids, and dust. Provide adequate ventilation in work areas to prevent accumulation of flammable gases, vapours, and dust.
7. Do not apply heat to a container that has held an unknown substance or a combustible material whose contents, when heated, can produce flammable or explosive vapours. Clean and purge containers before applying heat. Vent closed containers, including castings, before preheating, welding, or cutting.

Electricity Can Kill



DANGER!

Touching live electrical parts can cause fatal shocks or severe burns. The electrode and work circuit is electrically live whenever the output is on.

The input power circuit and machine internal circuits are also live when power is on. In semi-automatic or automatic wire welding, the wire, wire reel, drive roll housing, and all metal parts touching the welding wire are electrically live. Incorrectly installed or improperly grounded equipment is a hazard.

1. Do not touch live electrical parts.
2. Wear dry, hole-free insulating gloves and body protection.
3. Insulate yourself from the work and the ground using dry insulating mats or covers.
4. Disconnect input power before installing or servicing this equipment. Lock input power, disconnect switch open, or remove line fuses so power cannot be turned on accidentally.
5. Properly install and ground this equipment according to national, state, and local codes.
6. Turn off all equipment when not in use. Disconnect power to equipment if it will be left unattended or out of service.
7. Use fully insulated electrode holders. Never dip the holder in water to cool it or lay it down on the ground or the work surface. Do not touch holders connected to two welding machines at the same time or touch other people with the holder or electrode.
8. Do not use worn, damaged, undersized, or poorly spliced cables.
9. Do not wrap cables around your body.
10. Connect work piece to a good electrical ground.
11. Do not touch the electrode while in contact with the work (ground) circuit.
12. Use only well-maintained equipment. Repair or replace damaged parts as soon as practical.
13. In confined spaces or damp locations, do not use a welder with AC output unless equipped with a voltage reducer.

Arc rays from the welding process produce intense heat and strong ultraviolet rays that can burn eyes and skin. Use the following table to select the appropriate shade number for a Welding Helmet or Welding Face Shield.

Recommended Protective Filters for Electric Welding		
Description of Process	Approximate Range of Welding Current in Amps	Minimum Shade Number of Filter(s)
Manual Metal Arc Welding - Covered Electrodes (MMA)	Less than or equal to 100	8
	100 to 200	10
	200 to 300	11
	300 to 400	12
	Greater than 400	13
Gas Metal Arc Welding (GMAW) (MIG) other than Aluminium And Stainless Steel	Less than or equal to 150	10
	150 to 250	11
	250 to 300	12
	300 to 400	13
	Greater than 400	14
Gas Metal Arc Welding(GMAW) (MIG) Aluminium and Stainless Steel	Less than or equal to 250	12
	250 to 350	13
Gas Tungsten Arc Welding (GTAW) (TIG)	Less than or equal to 100	10
	100 to 200	11
	200 to 250	12
	250 to 350	13
	Greater than 350	14
Flux-Cored Arc Welding (FCAW) - with or without Shielding Gas	Less than or equal to 300	11
	300 to 400	12
	400 to 500	13
	Greater than 500	14
Air - Arc Gouging	Less than or equal to 400	12
Plasma - Arc Cutting	50 to 100	10
	100 to 400	12
	400 to 800	14
Plasma - Arc Spraying	—	15
Plasma - Arc Welding	Less than or equal to 20	8
	20 to 100	10
	100 to 400	12
	400 to 800	14
Submerged - Arc Welding	—	2 (5)
Resistance Welding	—	Safety Spectacles or Eye Shield

Refer to standard AS/NZS 1338.1 for comprehensive information regarding the above table.

Fumes And Gases



WARNING!

Welding produces fumes and gases. Breathing these fumes and gases can be hazardous to your health.

- Keep your head out of the fumes. Do not breathe the fumes.
- If inside, ventilate the area and/or use an exhaust at the arc to remove welding fumes and gases.
- If ventilation is poor, use an approved air-supplied respirator.
- Read the Safety Data Sheets (SDS) and the manufacturer's instruction for the metals, consumables, coatings, and cleaners.
- Work in a confined space only if it is well ventilated, or while wearing an air-supplied respirator. Shielding gases used for welding can displace air causing injury or death. Be sure the breathing air is safe.
- Do not weld in locations near degreasing, cleaning, or spraying operations. The heat and rays of the arc can react with vapours to form highly toxic and irritating gases.
- Do not weld on coated metals, such as galvanized, lead, or cadmium plated steel, unless the coating is removed from the weld area, the area is well ventilated, and if necessary, while wearing an air-supplied respirator. The coatings and any metals containing these elements can give off toxic fumes if welded.

Fire & Explosive Risks



WARNING!

Sparks and spatter fly off from the welding arc. The flying sparks and hot metal, weld spatter, work piece, and hot equipment can cause fires and burns.

Accidental contact of electrode or welding wire to metal objects can cause sparks, overheating, or fire.

1. Protect yourself and others from flying sparks and hot metal.
2. Do not weld where flying sparks can strike flammable material.
3. Remove all flammables within 10m of the welding site.
4. Be alert that welding sparks and hot materials from welding can easily go through small cracks and openings to adjacent areas.
5. Watch for fire, and keep a fire extinguisher nearby.
6. Be aware that welding on a ceiling, floor, bulkhead, or partition can cause fire on the hidden side.
7. Do not weld on closed containers such as tanks or drums.
8. Connect the work lead/clamp to the job as close to the welding area as practical to prevent welding current from travelling long, possibly unknown paths and causing electric shock and fire hazards.
9. Do not use a welder to thaw frozen pipes.
10. Remove the stick electrode from the holder or cut off the welding wire at the contact tip when not in use.

Sparks & Hot Metal



WARNING!

Chipping and grinding causes flying metal, and as welds cool they can throw off slag.

1. Wear an AS/NZS approved face shield or safety goggles. Side shields are recommended.
2. Wear appropriate safety equipment to protect the skin and body.

Cylinders



WARNING!

Gas cylinders contain gas under high pressure. If damaged, a cylinder can explode. Since gas cylinders are normally part of the welding

1. Protect compressed gas cylinders from excessive heat, mechanical shocks, and arcs.
2. Install and secure cylinders in an upright position by chaining them to a stationary support or equipment cylinder rack to prevent falling or tipping.
3. Keep cylinders away from any welding or other electrical circuits.
4. Never allow a welding electrode to touch any cylinder.
5. Use appropriate shielding gas, regulators, hoses, and fittings designed for the specific application; maintain them and their associated parts in good condition.
6. Turn your face away from the valve outlet when opening the cylinder valve.

WARRANTY

Duralloy Welding Equipment / Plasma Cutting Range

3 year Warranty*

Duralloy Industrial Supply warrants the original retail purchaser that the Duralloy Welding and Cutting machines purchased will be free from defects in materials and workmanship for a period of 3 years* from the date of purchase by the customer. If a defect in material or workmanship becomes evident during this period, Duralloy Industrial Supply will at its option;

- Repair the product (or pay for the repair of the product)
- Replace the product

In case of warranty claim the product should be returned to the original place of purchase, with proof of purchase.

Any handling and transport costs (or other expenses) incurred in claiming warranty are not covered by this warranty. The warranty schedule is:

- Duralloy Power source only* 3 years
- Duralloy Regulator 3 months
- MIG Torches 3 months
- TIG Torches 3 months
- Plasma Torches 3 months
- Ancillary Equipment 3 months

The Obligation of Duralloy Industrial Supply under this warranty is limited to the circumstance set out above and is subject to:

- The customer being able to provide proof of purchase of the relevant equipment.
- A defect in either material or workmanship.
- The customer returning the product to Duralloy Industrial supply or an authorized repair agent.
- The product not having been altered or tampered with.
- The product not having been used outside the normal operating parameters of this equipment.
- The product to be in good condition and not damaged which may cause a fault

All goods come with a guarantee that cannot be excluded under the Australian Consumer laws. You as a consumer are entitled to a replacement or a refund for a major failure. You are also entitled to have the goods repaired or replaced if the products fail to be of acceptable quality.

This Warranty Provided by:

Duralloy Industrial Supply ABN 81 831 839 268
2 Hollylea Road Leumeah NSW 2560
1300 369 456



DURALLOY®

www.duralloy.net.au | 1300 369 456